

## GH-S

Wirtschaftliches Entgraten und Anfasen von Bohrungen, vorwärts und rückwärts in einem Arbeitsgang



## GH-S

Economical bore deburring and chamfering, forward and reverse in a single work operation

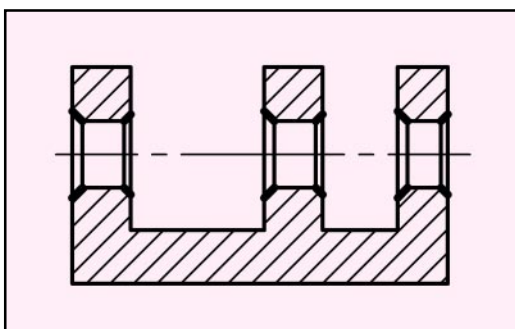
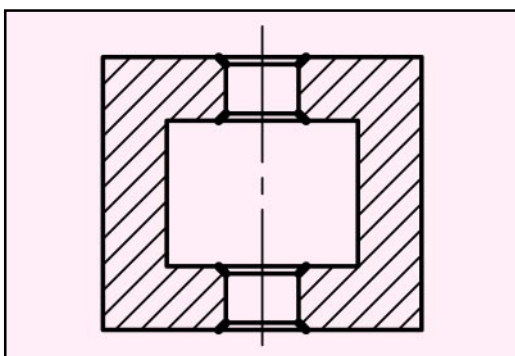

## GH-S



# HEULE

## WERKZEUG AG

CH-9436 Balgach/Switzerland

Internet [www.heule.com](http://www.heule.com)

E-Mail [info@heule.com](mailto:info@heule.com)

Phone +41 - 71 / 726 38 38

Fax +41 - 71 / 726 38 39

# 1 Werkzeugbeschreibung / Tool Description

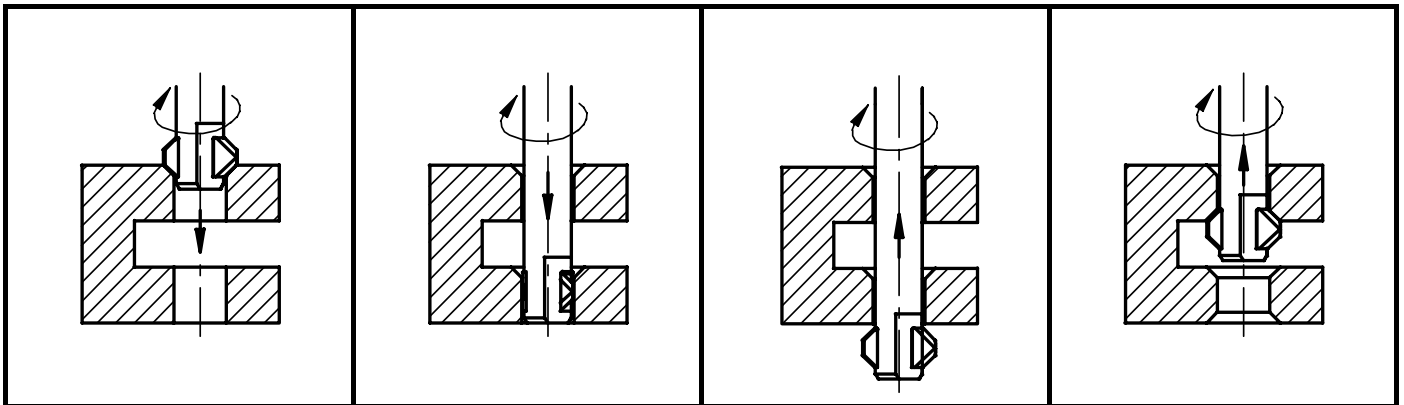

**Zwei Messer** sind im Werkzeugkopf über ein patentiertes Steuersystem **starr miteinander verbunden**. Dieses Steuersystem reagiert auf die progressiv ansteigende Schnittkraft. Die Schnittkraft ist von Werkstoffqualität und Fasengröße abhängig. Die entsprechende Kraft auf die beiden Messer kann am Werkzeug stufenlos eingestellt werden. **Übersteigt die Schnittkraft die eingestellte Messerkraft, ziehen sich die beiden Messer synchron in das Werkzeug zurück.** Durch das patentierte Steuersystem passiert das Senkwerkzeug die Bohrung mit stark reduzierter Messerkraft. Daher ist eine Beschädigung der Bohrungsoberfläche oder eines Gewindes ausgeschlossen. Beim Bohrungsausritt fahren die Messer in die Ausgangsstellung und verriegeln sich gegenseitig. Im Arbeitsvorschub rückwärts wird die hintere Bohrungskante bearbeitet.

**Die starre Verbindung der Schneidmesser bewirkt, dass Bohrungen mit einer Längsnute oder mit Querbohrungen bearbeitet und drehend durchfahren werden können.**

Mit dem GH-S Werkzeug kann mit normalen Vorschüben gearbeitet werden, ohne dass Vibrationen auftreten. Da sich die beiden Messer nicht einzeln verschieben lassen, werden auch **bei Bohrungen mit stark unterschiedlichen Gratbildungen einwandfreie Anfasungen** erzielt

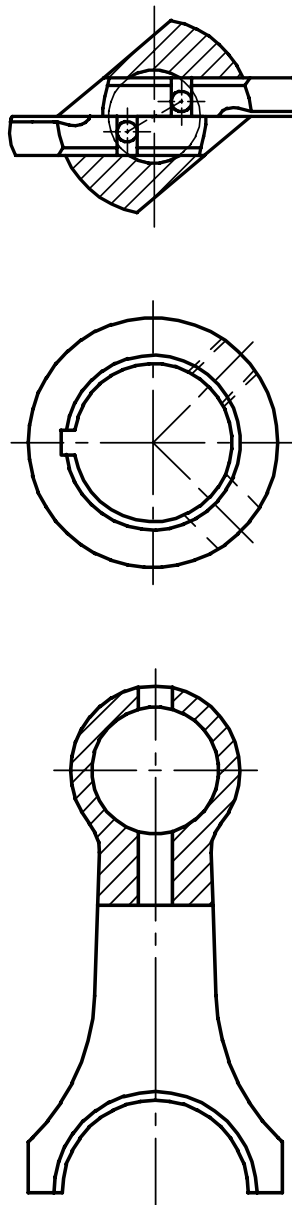

**Two blades are positively connected together** in the tool head by means of a patented control system. The control system reacts to the progressively increasing cutting force. The degree of reaction is influenced by the type of material being machined, and the size of the chamfer required on the workpiece. The required blade force at the two cutting blades is capable of infinite adjustments at the tool. **If the cutting force exceeds the set blade force, the two cutting blades retract simultaneously into the blade housing.** The patented control system allows the cutting blades to pass through the bore at a greatly reduced force on the side wall. Because of this, it is not possible for the bore surface or the threaded bore to sustain damage. After the tool exits the bore, beyond the burr, the cutting blades extend to the initial interlocking position. With back feed, the reverse side of the workpiece is machined.

**The positive actuation of the blades means that bores can be machined with a longitudinal slot, or cross hole with no tool deflection.**

With GH-S tools, it is possible to work with normal feeds, without vibrations occurring. The two cutting blades cannot be moved individually, **thus bores with a variety of burr formations can be completely chamfered with satisfactory results.**

## 2 Werkzeugauswahl / Tool Selection

Werkzeugbezeichnung Tool description	min. Bohr- $\varnothing$ min. bore $\varnothing$	Fasbereich bei Faswinkel 90° Chamfer range for chamfer angle 90°		Fasbereich bei Faswinkel 60° Chamfer range for chamfer angle 60°	
		D max. Fas- $\varnothing$ Chamfer $\varnothing$	$\varnothing$ D2	D max. Fas- $\varnothing$ Chamfer $\varnothing$	$\varnothing$ D2
GH-S	$\varnothing$ d				
16-18	16	20.0	20.2	18.6	18.8
18-20	18	22.0	22.2	20.4	20.6

Ganze Tabelle, siehe Seite 7  
D = Fasdurchmesser

Complete table, see page 7  
D = Chamfer diameter

<p><b><u>Werkzeugbezeichnung:</u></b> Definiert den Einsatzbereich des Werkzeuges bezogen auf den Bohrungsdurchmesser.</p> <p><b>Beispiel:</b> Das Werkzeug mit der Bezeichnung <b>GH-S 18-20</b> kann für den Bohrungsdurchmesserbereich von <math>\varnothing</math> 18mm bis <math>\varnothing</math> 20mm eingesetzt werden.</p> <p><b><u>Min. Bohr-<math>\varnothing</math> d:</u></b> Bestimmt den kleinsten Bohrungsdurchmesser, der mit diesem Werkzeug durchfahren werden darf.</p> <p><b><u>Fasbereich bei Senkwinkel 90° D max.:</u></b> Ist der theoretisch erreichbare Fasdurchmesser. Es ist zu berücksichtigen, dass die Fasengrösse vom Material, der eingestellten Messerkraft und dem Vorschub abhängig ist. Mit den GH-S Werkzeugen ist eine Fase, je nach Werkzeug- und Bohrdurchmesser, von 0.1mm bis 2.0mm erreichbar.</p> <p><b><u>Empfehlung:</u></b> Bei Bohrungen, welche den möglichen Bereich zweier Werkzeuge betreffen, wähle man stets das grössere Werkzeug aus.</p> <p><b>Beispiel:</b> Für Bohrungsdurchmesser 20mm wähle man das Werkzeug GH-S 20-22 (nicht GH-S 18-20).</p> <p><b><u>Bestellinformationen:</u></b> Für ein einsatzbereites Werkzeug wird immer das "Werkzeug ohne Messer, mit Schaft" + "Messer" <b>oder</b> "Werkzeug ohne Messer, ohne Schaft" + "Schaft" + "Messer" benötigt.</p> <p><b>Beispiel:</b> Bohrungsdurchmesser: 19mm; Material: Grauguss; Nutzlänge: 20mm; Aufnahme: Stelhülse Tr 28x2</p> <table border="0"> <tr> <td><b>Bestelltext:</b></td> <td><b>Bestell-Nr.:</b></td> </tr> <tr> <td>Werkzeug: GH-S 18-20/30 o.Schaft</td> <td>GH-S-O-1699</td> </tr> <tr> <td>StellhülSENSCHAFT:</td> <td></td> </tr> <tr> <td>Tr 28x2 GH-S 10-22</td> <td>GH-S-S-0105</td> </tr> <tr> <td>Messer: GH-S 18-20 HM 90°</td> <td>GH-S-M-1012</td> </tr> </table>	<b>Bestelltext:</b>	<b>Bestell-Nr.:</b>	Werkzeug: GH-S 18-20/30 o.Schaft	GH-S-O-1699	StellhülSENSCHAFT:		Tr 28x2 GH-S 10-22	GH-S-S-0105	Messer: GH-S 18-20 HM 90°	GH-S-M-1012
<b>Bestelltext:</b>	<b>Bestell-Nr.:</b>									
Werkzeug: GH-S 18-20/30 o.Schaft	GH-S-O-1699									
StellhülSENSCHAFT:										
Tr 28x2 GH-S 10-22	GH-S-S-0105									
Messer: GH-S 18-20 HM 90°	GH-S-M-1012									

<p><b><u>Tool description:</u></b> Defines the application range of the tool with reference to the bore diameter.</p> <p><b>Example:</b> The tool with the description <b>GH-S 18-20</b> can be used for the diameter range of bores from dia. 18mm up to 20mm.</p> <p><b><u>Min. bore <math>\varnothing</math> d:</u></b> Determines the smallest bore diameter which can be passed with this tool.</p> <p><b><u>Chamfer range for chamfer angle 90° D max.:</u></b> This is the theoretically possible chamfer diameter. Please consider that the chamfer size depends on the material to be machined, the set blade force and the feed rate. With GH-S tools a chamfer of 0.1mm to 2.0mm can be achieved, depending on the tool diameter and the bore diameter.</p> <p><b><u>Recommendation:</u></b> For bores touching the possible application range of two tools, we recommend to use always the larger tool.</p> <p><b>Example:</b> For bore diameter 20mm please select the tool GH-S 20-22 (not GH-S 18-20).</p> <p><b><u>Ordering information:</u></b> For a tool ready for operation you always need the "tool without blades, with shank" + "blades" <b>or</b> "tool without blades, without shank" + "shank" + "blades".</p> <p><b>Example:</b> Bore dia.: 19mm; Material: grey cast; Working length: 20mm; Adaption: automotive shank Tr 28x2</p> <table border="0"> <tr> <td><b>Order information:</b></td> <td><b>Order No.:</b></td> </tr> <tr> <td>Tool: GH-S 18-20/30 w/o shank</td> <td>GH-S-O-1699</td> </tr> <tr> <td>Automotive shank:</td> <td></td> </tr> <tr> <td>Tr 28x2 GH-S 10-22</td> <td>GH-S-S-0105</td> </tr> <tr> <td>Blades: GH-S 18-20 carbide 90°</td> <td>GH-S-M-1012</td> </tr> </table>	<b>Order information:</b>	<b>Order No.:</b>	Tool: GH-S 18-20/30 w/o shank	GH-S-O-1699	Automotive shank:		Tr 28x2 GH-S 10-22	GH-S-S-0105	Blades: GH-S 18-20 carbide 90°	GH-S-M-1012
<b>Order information:</b>	<b>Order No.:</b>									
Tool: GH-S 18-20/30 w/o shank	GH-S-O-1699									
Automotive shank:										
Tr 28x2 GH-S 10-22	GH-S-S-0105									
Blades: GH-S 18-20 carbide 90°	GH-S-M-1012									

### 3 Messerwechsel / Changing the blades

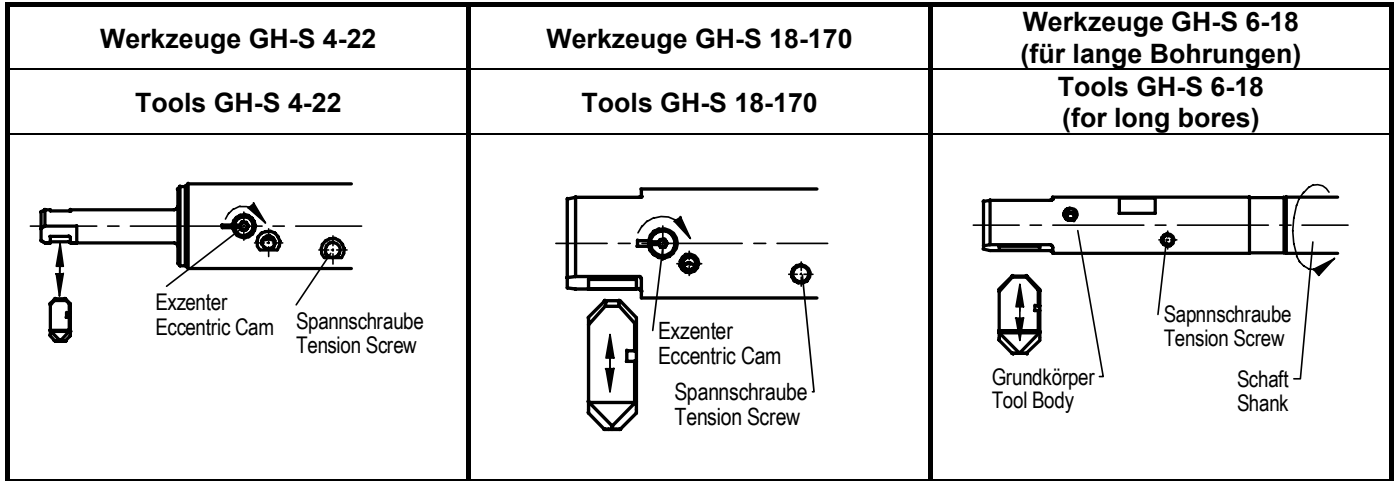

<p>Werkzeuge GH-S 4-22 Werkzeuge GH-S 18-170</p>
<ol style="list-style-type: none"> <li>Spannschraube nach links drehen bis sich die Messer <b>leicht</b> von Hand zusammendrücken lassen. <b>Nur bei entspannten Messern Messerwechsel vornehmen.</b></li> <li>Exzenter um 180° drehen bis die Kerbe in Richtung Schaft zeigt.</li> <li>Messer aus Werkzeug herauschieben.</li> <li>Ersatzmesser, sauber gereinigt und entmagnetisiert, so einschieben, dass sie etwa bündig mit dem Aussendurchmesser des Werkzeuges stehen.</li> <li>Exzenter wieder zurück drehen bis <b>leichter</b> Widerstand spürbar wird.</li> <li>Messer in Arbeitsrichtung verschieben bis diese selbständig einrasten.</li> <li><b>Kontrolle:</b> Beide Messer müssen sich synchron bewegen.</li> <li>Spannschraube soweit nach rechts drehen bis gewünschte Messerkraft erreicht ist.</li> </ol>
<p>Werkzeuge GH-S 6-18 (für lange Bohrungen)</p>
<ol style="list-style-type: none"> <li>Spannschraube nach links drehen bis sich die Messer <b>leicht</b> von Hand zusammendrücken lassen. <b>Nur bei entspannten Messern Messerwechsel vornehmen.</b></li> <li>Schaft vom Grundkörper durch 2-3 Umdrehungen nach links lösen (bis zu Anschlag drehen).</li> <li>Messer aus Werkzeug herauschieben.</li> <li>Ersatzmesser, sauber gereinigt und entmagnetisiert, so einschieben, dass sie etwa bündig mit dem Aussendurchmesser des Werkzeuges stehen.</li> <li>Schaft nach rechts eindrehen und mit Gabelschlüssel leicht festziehen.</li> <li>Messer in Arbeitsrichtung verschieben bis diese selbständig einrasten.</li> <li><b>Kontrolle:</b> Beide Messer müssen sich synchron bewegen.</li> <li>Spannschraube soweit nach rechts drehen bis gewünschte Messerkraft erreicht ist.</li> </ol>

<p>Tools GH-S 4-22 Tools GH-S 18-170</p>
<ol style="list-style-type: none"> <li>Continue to turn the tension screw counter-clockwise until it is possible to press the blades together <b>easily</b> by hand. <b>Only change the blades when they are slack, i.e. when they are not under tension.</b></li> <li>Turn the eccentric cam 180° until the notch is facing opposite of the index.</li> <li>Remove blades from blade housing (by pushing).</li> <li>Insert the replacement blades as a pair, cleaned and demagnetized, so that they are approximately flush with the outside diameter of the blade housing.</li> <li>Turn the eccentric cam back to the left until a <b>slight</b> resistance is noticed (register).</li> <li>Move the inserted blades in the working direction (arrow) until they engage automatically.</li> <li><b>Check:</b> Both blades must move synchronously.</li> <li>Continue to turn tension screw clockwise until the desired blade force is attained.</li> </ol>
<p>Tools GH-S 6-18 (for long bores)</p>
<ol style="list-style-type: none"> <li>Continue to turn the tension screw counter-clockwise until it is possible to press the blades together <b>easily</b> by hand. <b>Only change the blades when they are slack, i.e. when they are not under tension.</b></li> <li>Slacken shank from tool body and rotate two or three turns by hand counter-clockwise, as far as the stop.</li> <li>Remove blades from blade housing (by pushing).</li> <li>Insert the replacement blades as a pair, cleaned and demagnetized, so that they are approximately flush with the outside diameter of the blade housing.</li> <li>Turn shank in clockwise and lightly tighten with spanner.</li> <li>Move the inserted blades in the working direction (arrow) until they engage automatically.</li> <li><b>Check:</b> Both blades must move synchronously.</li> <li>Continue to turn tension screw clockwise until the desired blade force is attained.</li> </ol>

## 4 Einstellen der Fasengrösse / Setting the chamfer size

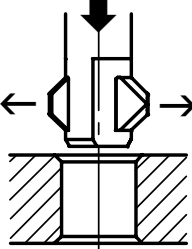
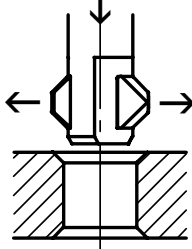
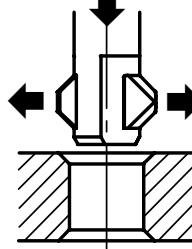
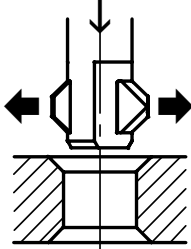
<b>kleine Fase:</b> - kleine Messerkraft - grosser Vorschub	<b>mittlere Fase:</b> - kleine Messerkraft - kleiner Vorschub	<b>mittlere Fase:</b> - grosse Messerkraft - grosser Vorschub	<b>grosse Fase:</b> - grosse Messerkraft - kleiner Vorschub
			
<b>small chamfer:</b> - small blade force - high feed rate	<b>medium chamfer:</b> - small blade force - small feed rate	<b>medium chamfer:</b> - high blade force - high feed rate	<b>large chamfer:</b> - high blade force - low feed rate

## 5 Einstellen der Messerkraft / Setting the blade force

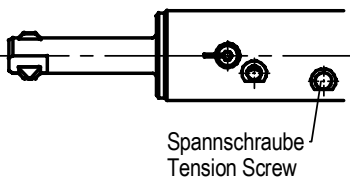
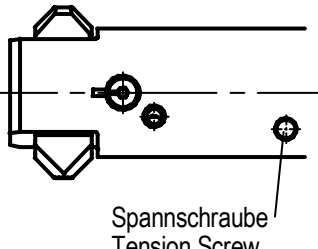
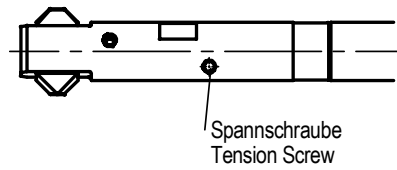
Werkzeuge GH-S 4-22	Werkzeuge GH-S 18-170	Werkzeuge GH-S 6-18 (für lange Bohrungen)
Tools GH-S 4-22	Tools GH-S 18-170	Tools GH-S 6-18 (for long bores)
		
Messerkraft erhöhen: Spanschraube nach rechts drehen		Increase blade force: Turn tension screw clockwise
Messerkraft senken: Spanschraube nach links drehen		Reduce blade force: Turn tension screw counter-clockwise

## 6 GH-S Schnittdaten / GH-S Cutting data

Richtwerte / Standard values

Werkstoff Material	Schnittgeschwindigkeit v (m/min.) bei Cutting speed v (m/min.) for			Vorschub s (mm/U) Feed s (mm/rev.)
	HSS-E	HSS-E-TIN	HM / Carbide	
Stahl, Stahllegierungen Steel, steel alloys	25-35	30-40	40-60	0.1-0.2
Guss, Gusseisenwerkstoffe Cast, cast iron materials	25-35	30-40	40-60	0.1-0.3
Nichteisen-Metalle Non-ferrous metals	40-60	50-70	60-80	0.1-0.3

## 7 Programmierhinweise / Programming information

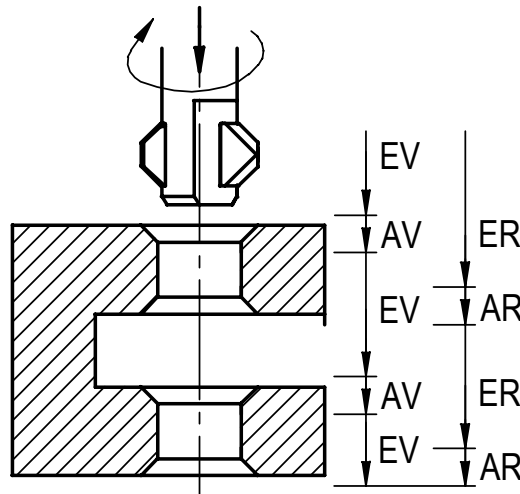

Bei der ganzen Bearbeitung ist keine Drehrichtungsänderung oder Stillstand der Spindel nötig.

**AV:** Arbeitsvorschub, vorwärts  
**EV:** Eilvorschub, vorwärts  
**AR:** Arbeitsvorschub, rückwärts  
**ER:** Eilvorschub, rückwärts

It is not necessary to change the sense of rotation or to stop the spindle.

**AV:** Working feed, forwards  
**EV:** Rapid feed, forwards  
**AR:** Working feed, backwards  
**ER:** Rapid feed, backwards

### 1. EV:

Das Werkzeug wird im Eilvorschub bis **vor** die Bohrungs- bzw. mögliche Gratkante positioniert.

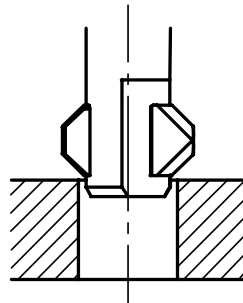

### 1. EV:

Rapid travers of the cutting unit of the tool **above** the top material surface of bore or burr.

### 2. AV:

Im Arbeitsvorschub wird die Fase erstellt. Es wird solange im Arbeitsvorschub gefahren, bis die Messer ganz zusammengefahren sind.

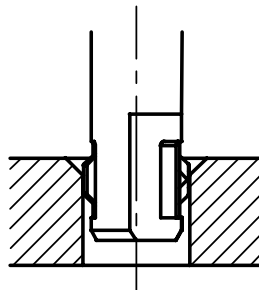

### 2. AV:

In forward working feed the chamfer is executed. Continue in working feed until the blades are completely retracted into the tool.

Die weiteren Schritte laufen für Folgebohrungen gleich ab wie oben angegeben, vorwärts und rückwärts.

For following bores the next steps are the same as written above, forwards and backwards.

# 8 GH-S Senkwerkzeuge / GH-S Chamfering Tools

## 8.1 GH-S Senkwerkzeuge 4-10 / GH-S Chamfering Tools 4-10

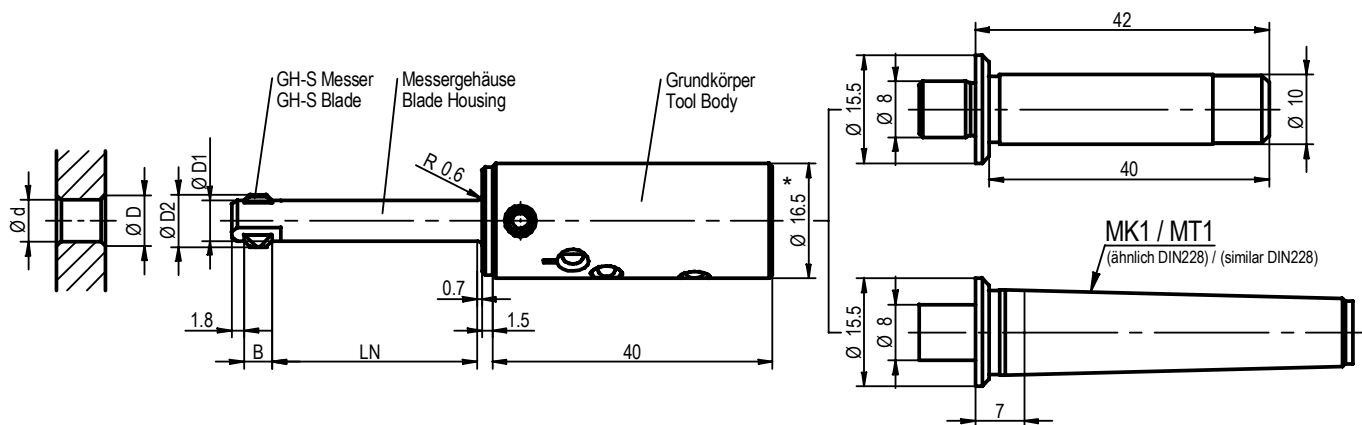

\* Ø16.0 auf Anfrage erhältlich / Ø16.0 on request

Werkzeugbezeichnung (Bohrungsbereich) Tool description (bore range)	min. Bohrø	Fasbereich bei Faswinkel 90°		Fasbereich bei Faswinkel 60°			Messergehäuse		Best. Nr. o. Messer o. Schaft	Best. Nr. o. Messer m. zyl. Schaft ø 10	Best. Nr. o. Messer m. MK1 Schaft
	min. bore ø	Chamfer range for chamfer 90°		Chamfer range for chamfer 60°			Blade Housing		Order No. w/o blades w/o shank	Order No. w/o blades w. cyl. shank ø 10	Order No. w/o blades w. MT1 shank
GH-S	ø d	D max.** Fas-ø Chamfer ø	ø D2*	D max.** Fas-ø Chamfer ø	ø D2	B	ø D1	LN	GH-S-O-	GH-S-O-	GH-S-O-
4 - 4.5/15								15	1600	1606	1603
4 - 4.5/30	4	5.1	5.2	5.0	5.1	3.2	3.8	30	1601	1607	1604
4 - 4.5/60								60	1602	1608	1605
4.5 - 5/15								15	1609	1615	1612
4.5 - 5/30	4.5	6.0	6.1	5.5	5.6	3.2	4.3	30	1610	1616	1613
4.5 - 5/60								60	1611	1617	1614
5 - 5.5/15								15	1618	1624	1621
5 - 5.5/30	5	6.5	6.6	6.0	6.1	3.2	4.8	30	1619	1625	1622
5 - 5.5/60								60	1620	1626	1623
5.5 - 6/15								15	1627	1633	1630
5.5 - 6/30	5.5	7.0	7.1	6.5	6.6	3.2	5.3	30	1628	1634	1631
5.5 - 6/60								60	1629	1635	1632
6 - 7/20								20	1636	1642	1639
6 - 7/34	6	7.3	7.4	7.3	7.4	4.0	5.8	34	1637	1643	1640
6 - 7/60								60	1638	1644	1641
7 - 8/20								20	1645	1651	1648
7 - 8/34	7	8.3	8.4	8.0	8.1	4.0	6.5	34	1646	1652	1649
7 - 8/60								60	1647	1653	1650
8 - 10/20								20	1654	1660	1657
8 - 10/34	8	11.0	11.2	10.0	10.2	6.0	7.5	34	1655	1661	1658
8 - 10/60								60	1656	1662	1659

\* Im Werk eingestellter D2 darf nicht verstellt werden

\*\* Erreichbare Fasengröße ist abhängig von Material, Messerkraft und Vorschub; ca. 0.1-0.6mm

Messer zu diesen GH-S Werkzeugen finden Sie auf den Seiten 17-18  
Säfte zu diesen GH-S Werkzeugen finden Sie auf den Seiten 21-22

\* Preset dia. D2 must not be changed

\*\* Attainable chamfer size depends on material, blade force and feed rate; approx. 0.1-0.6mm

Blades for these GH-S tools please find on pages 17-18  
Shanks for these GH-S tools please find on pages 21-22

## 8.2 GH-S Senkwerkzeuge 10-22 / GH-S Chamfering Tools 10-22

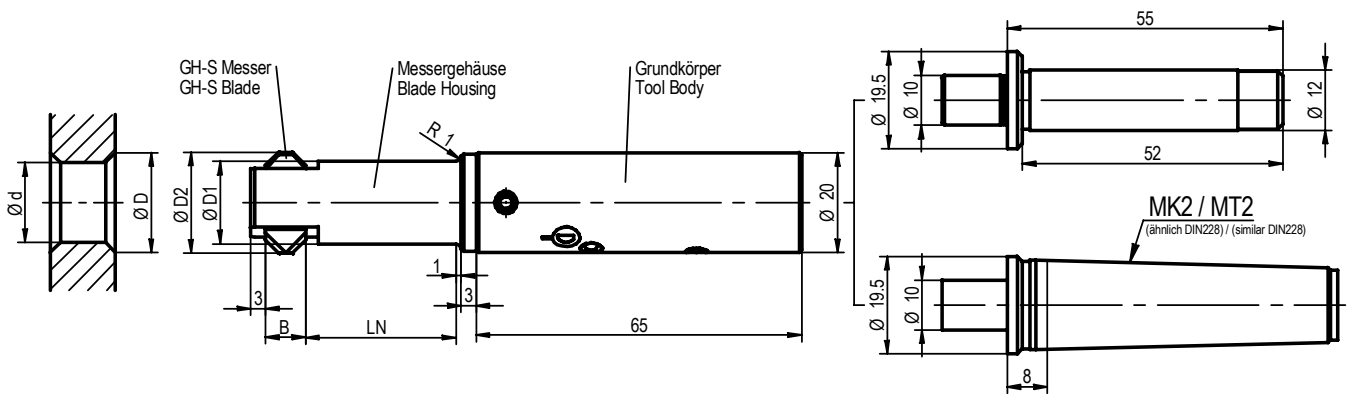

Werkzeug- bezeichnung (Bohrungs- bereich) <b>Tool description (bore range)</b>	min. Bohrø  min. bore ø	Fasbereich bei Faswinkel 90°		Fasbereich bei Faswinkel 60°		B	Messerge- häuse		Best. Nr. o. Messer o. Schaft	Best. Nr. o. Messer m. zyl. Schaft ø 12	Best. Nr. o. Messer m. MK2 - Schaft
		Chamfer range for chamfer 90°		Chamfer range for chamfer 60°			Blade Housing	Order No. w/o blades w/o shank	Order No. w/o blades w. cyl. shank ø 12	Order No. w/o blades w. MT2 - shank	
<b>GH-S</b>	ø d	D max.** Fas-ø Chamfer ø	ø D2*	D max.** Fas-ø Chamfer ø	ø D2*	ø D1	LN	GH-S-O-	GH-S-O-	GH-S-O-	
<b>10 - 12/30</b>	10	13.0	13.2	12.0	12.2	6.0	9.5	30	1663	1669	1666
<b>10 - 12/60</b>								60	1664	1670	1667
<b>10 - 12/100</b>								100	1665	1671	1668
<b>12 - 14/30</b>	12	16.0	16.2	14.6	14.8	8.0	11	30	1672	1678	1675
<b>12 - 14/60</b>								60	1673	1679	1676
<b>12 - 14/100</b>								100	1674	1680	1677
<b>14 - 16/30</b>	14	18.0	18.2	16.6	16.8	8.0	13	30	1681	1687	1684
<b>14 - 16/60</b>								60	1682	1688	1685
<b>14 - 16/100</b>								100	1683	1689	1686
<b>16 - 18/30</b>	16	20.0	20.2	18.6	18.8	8.0	15	30	1690	1696	1693
<b>16 - 18/60</b>								60	1691	1697	1694
<b>16 - 18/100</b>								100	1692	1698	1695
<b>18 - 20/30</b>	18	22.0	22.2	20.4	20.6	8.0	16.5	30	1699	1705	1702
<b>18 - 20/60</b>								60	1700	1706	1703
<b>18 - 20/100</b>								100	1701	1707	1704
<b>20 - 22/30</b>	20	24.0	24.3	22.4	22.6	8.0	18.5	30	1708	1714	1711
<b>20 - 22/60</b>								60	1709	1715	1712
<b>20 - 22/100</b>								100	1710	1716	1713

\* Im Werk eingestellter D2 darf nicht verstellt werden

\*\* Erreichbare Fasengröße ist abhängig von Material, Messerkraft und Vorschub; ca. 0.1-1.0mm

Messer zu diesen GH-S Werkzeugen finden Sie auf den Seiten 17-18  
Schäfte zu diesen GH-S Werkzeugen finden Sie auf den Seiten 23-24

\* Preset dia. D2 must not be changed

\*\* Attainable chamfer size depends on material, blade force and feed rate; approx. 0.1-1.0mm

Blades for these GH-S tools please find on pages 17-18  
Shanks for these GH-S tools please find on pages 23-24

## 8.3 GH-S Senkwerkzeuge 18-42 / GH-S Chamfering Tools 18-42

### 8.3.1 GH-S Senkwerkzeuge 18-42, ohne Messer, ohne Schaft GH-S Chamfering Tools 18-42, w/o blades, w/o shank

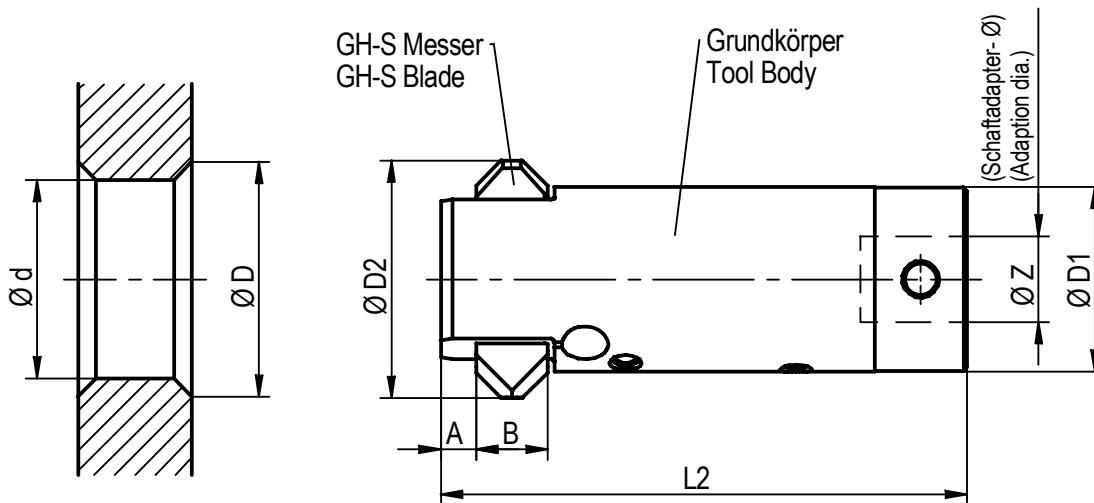

Werkzeug- bezeichnung (Bohrungs- bereich) Tool description (bore range)  GH-S	min. Bohrø	Fasbereich bei Faswinkel 90°		Fasbereich bei Faswinkel 60°							Best. Nr.
	min. boreø	Chamfer range for chamfer 90°		Chamfer range for chamfer 60°							Order No.
	Ø d	D max.** Fas-ø Chamfer ø	Ø D2*	D max.** Fas-ø Chamfer ø	Ø D2*	A	B	Ø D1	Ø Z	L2	GH-S-O-
18 - 20	18	22.0	22.2	20.4	20.6	3	8	16.5	8.0	62	1717
20 - 22	20	24.0	24.3	22.3	22.6	3	8	18.5	8.0	62	1720
22 - 25	22	27.0	27.3	25.1	25.4	4	9	20.5	10.0	65	1723
25 - 28	25	30.0	30.2	28.1	28.4	4	9	23	10.0	65	1726
28 - 31	28	33.0	33.4	30.7	31.0	5	10	26	12.0	74	1729
31 - 34	31	36.0	36.4	34.0	34.4	5	10	29	12.0	74	1732
34 - 38	34	40.0	40.4	37.6	38.0	6	10	32	18.0	79	1735
38 - 42	38	44.0	44.4	41.8	42.2	6	10	36	18.0	79	1738

\* Im Werk eingestellter D2 darf nicht verstellt werden

\*\* Erreichbare Fasengröße ist abhängig von Material, Messerkraft und Vorschub; ca. 0.1-1.5mm

Messer zu diesen GH-S Werkzeugen finden Sie auf den Seiten 17-20  
Säfte zu diesen GH-S Werkzeugen finden Sie auf den Seiten 25-28

\* Preset dia. D2 must not be changed

\*\* Attainable chamfer size depends on material, blade force and feed rate; approx. 0.1-1.5mm

Blades for these GH-S tools please find on pages 17-20  
Shanks for these GH-S tools please find on pages 25-28

### 8.3.2 GH-S Senkwerkzeuge 18-42, ohne Messer, mit Weldon Schaft GH-S Chamfering Tools 18-42, w/o blades, with Weldon shank

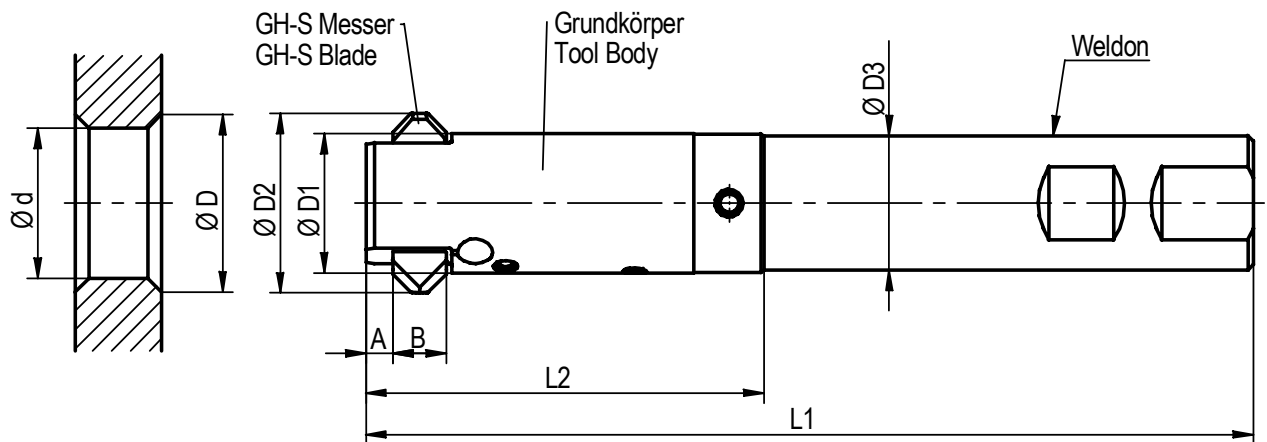

Werkzeug- bezeichnung (Bohrungs- bereich) Tool description (bore range)	min. Bohrø	Fasbereich bei Faswinkel 90°		Fasbereich bei Faswinkel 60°		A	B	ø D1	ø D3	L1	L2	Wel- don	Best. Nr.
	min. boreø	Chamfer range for chamfer 90°		Chamfer range for chamfer 60°									Order No.
GH-S	ø d	D max.** Fas-ø Chamfer ø	ø D2*	D max.** Fas-ø Chamfer ø	ø D2*								GH-S-O-
<b>18 - 20</b>	18	22.0	22.2	20.4	20.6	3	8	16.5	16.0	153	62	16	1718
<b>20 - 22</b>	20	24.0	24.3	22.3	22.6	3	8	18.5	16.0	153	62	16	1721
<b>22 - 25</b>	22	27.0	27.3	25.1	25.4	4	9	20.5	20.0	158	65	20	1724
<b>25 - 28</b>	25	30.0	30.2	28.1	28.4	4	9	23	20.0	158	65	20	1727
<b>28 - 31</b>	28	33.0	33.4	30.7	31.0	5	10	26	25.0	165	74	25	1730
<b>31 - 34</b>	31	36.0	36.4	34.0	34.4	5	10	29	25.0	165	74	25	1733
<b>34 - 38</b>	34	40.0	40.4	37.6	38.0	6	10	32	32.0	184	79	25	1736
<b>38 - 42</b>	38	44.0	44.4	41.8	42.2	6	10	36	32.0	184	79	25	1739

\* Im Werk eingestellter D2 darf nicht verstellt werden

\*\* Erreichbare Fasengröße ist abhängig von Material, Messerkraft und Vorschub; ca. 0.1-1.5mm

Messer zu diesen GH-S Werkzeugen finden Sie auf den Seite 17-20  
Säfte zu diesen GH-S Werkzeugen finden Sie auf den Seiten 25-28

\* Preset dia. D2 must not be changed

\*\* Attainable chamfer size depends on material, blade force and feed rate; approx. 0.1-1.5mm

Blades for these GH-S tools please find on pages 17-20  
Shanks for these GH-S tools please find on pages 25-28

### 8.3.3 GH-S Senkwerkzeuge 18-42, ohne Messer, mit MK Schaft GH-S Chamfering Tools 18-42, w/o blades, with MT shank

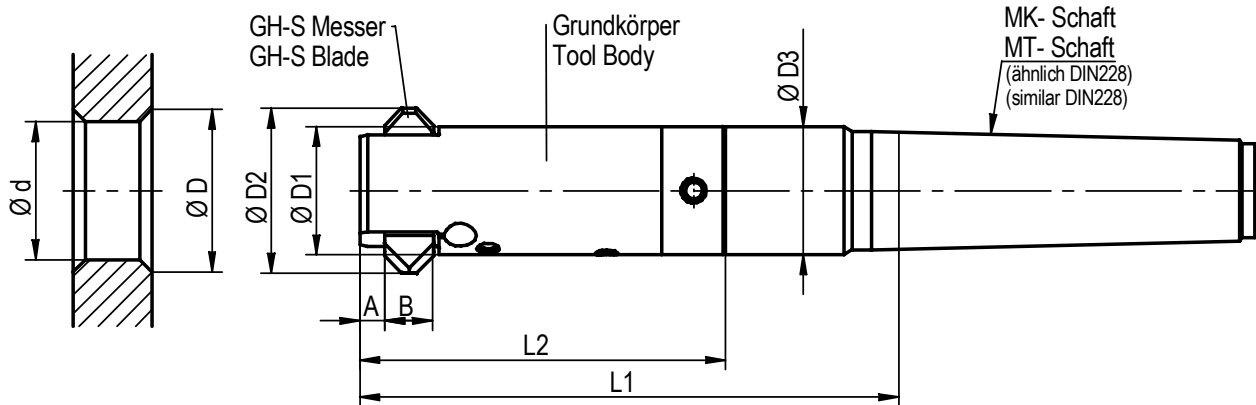

Werkzeug- bezeichnung (Bohrungs- bereich) <b>Tool description (bore range)</b>	min. Bohrø	Fasbereich bei Faswinkel 90°		Fasbereich bei Faswinkel 60°									Best. Nr.
	min. boreø	Chamfer range for chamfer 90°		Chamfer range for chamfer 60°									Order No.
<b>GH-S</b>	ø d	D max.** Fas-ø Chamfer ø	ø D2*	D max.** Fas-ø Chamfer ø	ø D2*	A	B	ø D1	ø D3	L1	L2	MK MT	GH-S-O-
<b>18 - 20</b>	18	22.0	22.2	20.4	20.6	3	8	16.5	16.5	105	62	2	1719
<b>20 - 22</b>	20	24.0	24.3	22.3	22.6	3	8	18.5	16.5	105	62	2	1722
<b>22 - 25</b>	22	27.0	27.3	25.1	25.4	4	9	20.5	20.5	108	65	2	1725
<b>25 - 28</b>	25	30.0	30.2	28.1	28.4	4	9	23	20.5	108	65	2	1728
<b>28 - 31</b>	28	33.0	33.4	30.7	31	5	10	26	26.0	109	74	3	1731
<b>31 - 34</b>	31	36.0	36.4	34.0	34.4	5	10	29	26.0	109	74	3	1734
<b>34 - 38</b>	34	40.0	40.4	37.6	38	6	10	32	32.0	126	79	3	1737
<b>38 - 42</b>	38	44.0	44.4	41.8	42.2	6	10	36	32.0	126	79	3	1740

\* Im Werk eingestellter D2 darf nicht verstellt werden

\*\* Erreichbare Fasengröße ist abhängig von Material, Messerkraft und Vorschub; ca. 0.1-1.5mm

Messer zu diesen GH-S Werkzeugen finden Sie auf den Seiten 17-20  
Säfte zu diesen GH-S Werkzeugen finden Sie auf den Seiten 25-28

\* Preset dia. D2 must not be changed

\*\* Attainable chamfer size depends on material, blade force and feed rate; approx. 0.1-1.5mm

Blades for these GH-S tools please find on pages 17-20  
Shanks for these GH-S tools please find on pages 25-28

## 8.4 GH-S Senkwerkzeuge 42-100 / GH-S Chamfering Tools 42-100

### 8.4.1 GH-S Senkwerkzeuge 42-100, ohne Messer, ohne Schaft GH-S Chamfering Tools 42-100, w/o blades, w/o shank

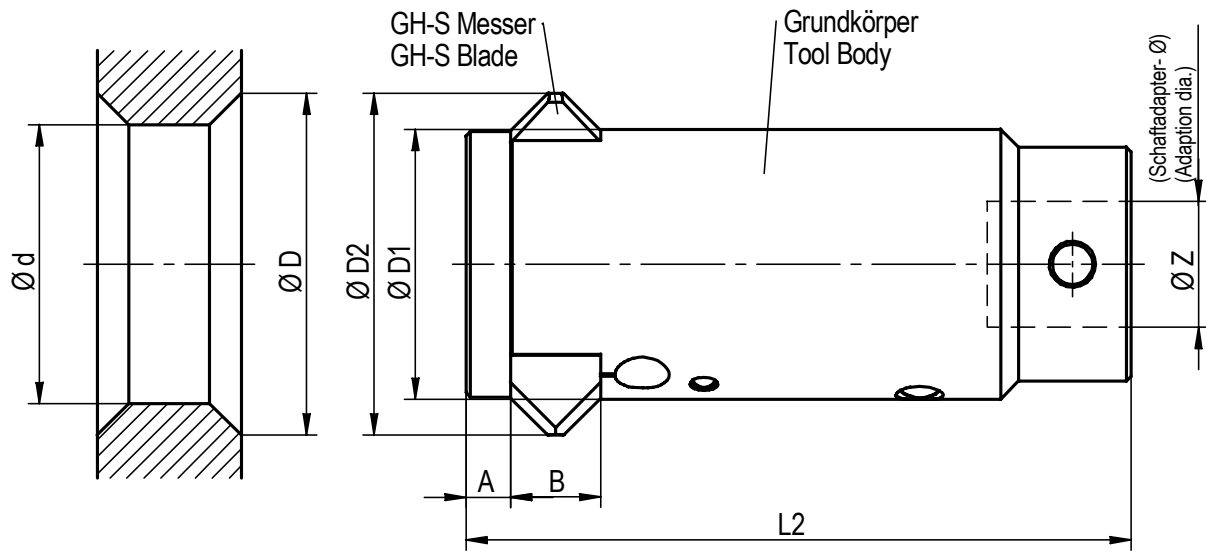

Werkzeug- bezeichnung (Bohrungsbereich)	min. Bohrø	Fasbereich bei Faswinkel 90°							Best. Nr.
Tool description (bore range)	min. boreø	Chamfer range for chamfer 90°							Order No.
GH-S	$\varnothing d$	D max.** Fas-ø Chamfer ø	$\varnothing D2^*$	A	B	$\varnothing D1$	$\varnothing Z$	L2	GH-S-O-
<b>42 - 48</b>	42	52	52.6	8	16	40	22	130	1741
<b>48 - 54</b>	48	58	58.6	8	16	46	22	130	1744
<b>54 - 62</b>	54	68	68.5	10	20	52	28	148	1747
<b>62 - 70</b>	62	76	76.5	10	20	60	28	148	1750
<b>70 - 80</b>	70	88	88.5	12	24	68	36	180	1753
<b>80 - 90</b>	80	98	98.5	12	24	78	36	180	1756
<b>90 - 100</b>	90	108	108.5	12	24	88	36	180	1759

\* Im Werk eingestellter D2 darf nicht verstellt werden

\*\* Erreichbare Fasengröße ist abhängig von Material, Messerkraft und Vorschub; ca. 0.2-2.0mm

Messer zu diesen GH-S Werkzeugen finden Sie auf den Seiten 19-20  
Säfte zu diesen GH-S Werkzeugen finden Sie auf den Seiten 29-30

\* Preset dia. D2 must not be changed

\*\* Attainable chamfer size depends on material, blade force and feed rate; approx. 0.2-2.0mm

Blades for these GH-S tools please find on pages 19-20  
Shanks for these GH-S tools please find on pages 29-30

**8.4.2 GH-S Senkwerkzeuge 42-100, ohne Messer, mit Weldon Schaft**  
**GH-S Chamfering Tools 42-100, w/o blades, with Weldon shank**

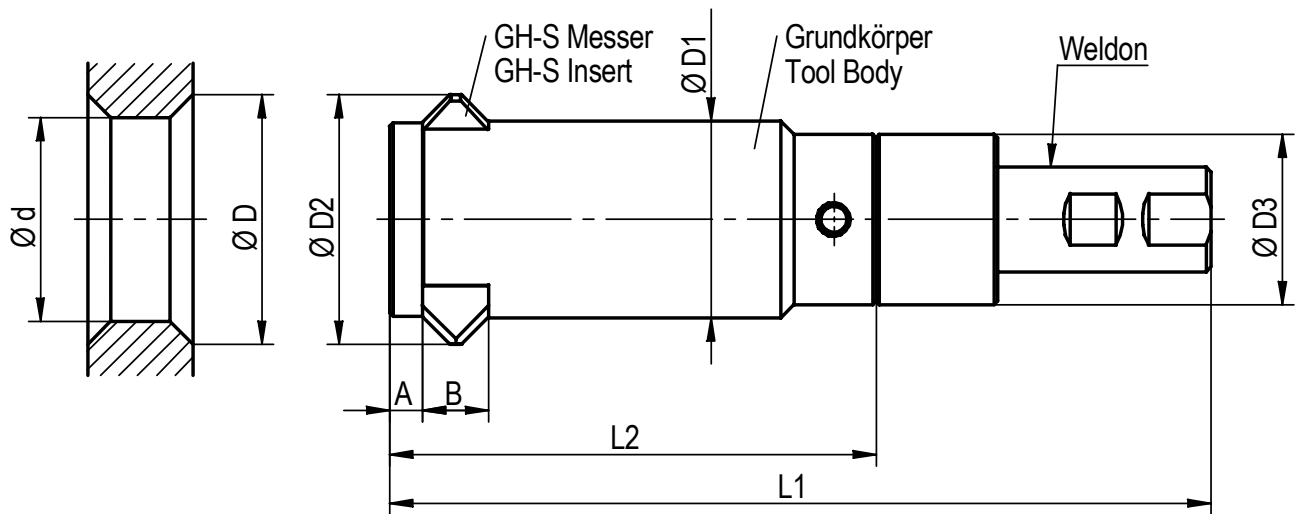

Werkzeug- bezeichnung (Bohrungs- bereich)	min. Bohrø	Fasbereich bei Faskwinkel 90°										Best. Nr.
	min. boreø	Chamfer range for chamfer 90°										Order No.
GH-S	ø d	D max.** Fas-ø Chamfer ø	ø D2*	A	B	ø D1	ø D3	L1	L2	Wel- don	GH-S-O-	
<b>42 - 48</b>	42	52	52.6	8	16	40	40	230	130	32	1742	
<b>48 - 54</b>	48	58	58.6	8	16	46	40	230	130	32	1745	
<b>54 - 62</b>	54	68	68.5	10	20	52	52	250	148	32	1748	
<b>62 - 70</b>	62	76	76.5	10	20	60	52	250	148	32	1751	
<b>70 - 80</b>	70	88	88.5	12	24	68	68	290	180	40	1754	
<b>80 - 90</b>	80	98	98.5	12	24	78	68	290	180	40	1757	
<b>90 - 100</b>	90	108	108.5	12	24	88	68	290	180	40	1760	

\* Im Werk eingestellter D2 darf nicht verstellt werden  
 \*\* Erreichbare Fasengröße ist abhängig von Material, Messerkraft und Vorschub; ca. 0.2-2.0mm  
 Messer zu diesen GH-S Werkzeugen finden Sie auf den Seiten 19-20  
 Schäfte zu diesen GH-S Werkzeugen finden Sie auf den Seiten 29-30

\* Preset dia. D2 must not be changed  
 \*\* Attainable chamfer size depends on material, pressure and feed rate; approx. 0.2-2.0mm  
 Blades for these GH-S tools please find on pages 19-20  
 Shanks for these GH-S tools please find on pages 29-30

**8.4.3 GH-S Senkwerkzeuge 42-100, ohne Messer, mit MK4 Schaft  
GH-S Chamfering Tool 42-100, w/o blades, with MT4 shank**

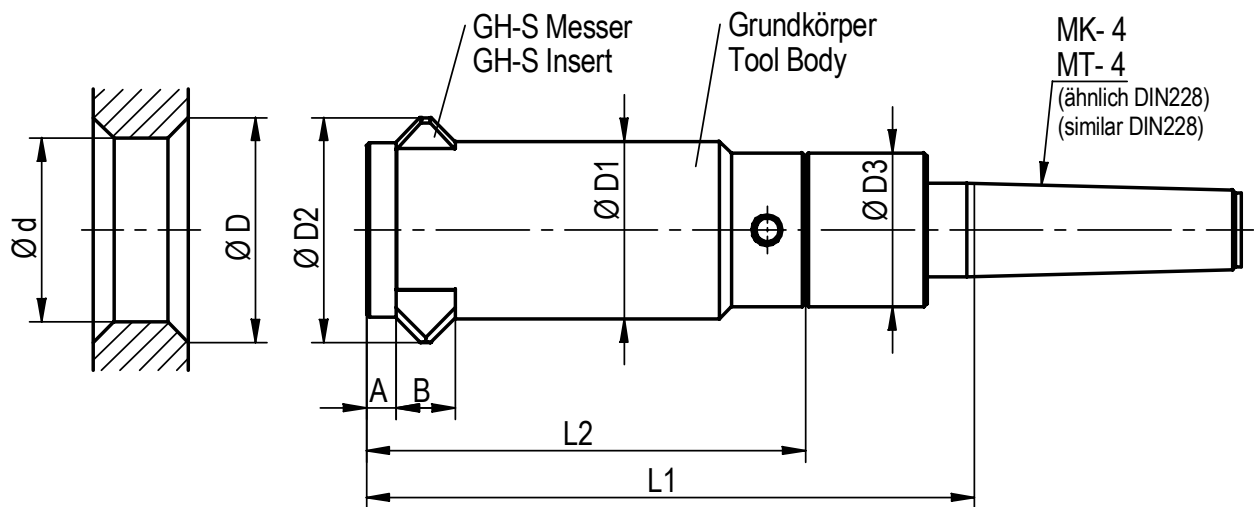

Werkzeug- bezeichnung (Bohrungs- bereich) Tool description (bore range)	min. Bohrø	Fasbereich bei Senkwinkel 90°								Best. Nr.
	min. boreø	Chamfer range for chamfer 90°								Order No.
GH-S	ø d	D max.** Fas-ø Chamfer ø	ø D2*	A	B	ø D1	ø D3	L1	L2	GH-S-O-
<b>42 - 48</b>	42	52	52.6	8	16	40	40	180	130	1743
<b>48 - 54</b>	48	58	58.6	8	16	46	40	180	130	1746
<b>54 - 62</b>	54	68	68.5	10	20	52	52	205	148	1749
<b>62 - 70</b>	62	76	76.5	10	20	60	52	205	148	1752
<b>70 - 80</b>	70	88	88.5	12	24	68	68	250	180	1755
<b>80 - 90</b>	80	98	98.5	12	24	78	68	250	180	1758
<b>90 -100</b>	90	108	108.5	12	24	88	68	250	180	1761

\* Im Werk eingestellter D2 darf nicht verstellt werden  
 \*\* Erreichbare Fasengröße ist abhängig von Material, Messerkraft und  
 Vorschub; ca. 0.2-2.0mm  
 Messer zu diesen GH-S Werkzeugen finden Sie auf den Seiten 19-20  
 Schäfte zu diesen GH-S Werkzeugen finden Sie auf den Seiten 29-30

\* Preset dia. D2 must not be changed  
 \*\* Attainable chamfer size depends on material, blade force and feed  
 rate; approx. 0.2-2.0mm  
 Blades for these GH-S tools please find on pages 19-20  
 Shanks for these GH-S tools please find on pages 29-30

## 8.5 GH-S Senkwerkzeuge 6-18 / GH-S Chamfering Tools 6-18

**Wichtig:** diese Werkzeuggruppe sollte nur für Anwendungen eingesetzt werden, bei denen kein anderer Werkzeugtyp verwendet werden kann.

**Important:** use this group of tools only for applications if you have no other possibility.

### 8.5.1 GH-S Senkwerkzeuge 6-18, ohne Messer, mit zylindrischem Schaft GH-S Chamfering Tools 6-18, w/o blades, with cylindrical shank

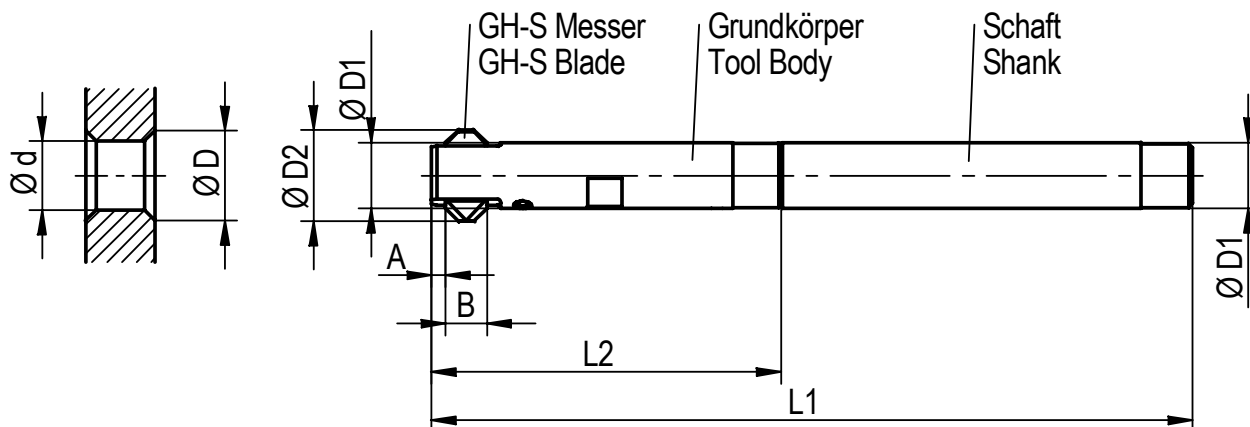

Werkzeug- bezeichnung (Bohrungs- bereich) Tool description (bore range)	min. Bohrø	Fasbereich bei Faswinkel 90°		Fasbereich bei Faswinkel 60°		A	B	ø D1	L1	L2	Best. Nr.
	min. boreø	Chamfer range for chamfer 90°		Chamfer range for chamfer 60°							Order No.
GH-S	ø d	D max.** Fas-ø Chamfer ø	ø D2*	D max.** Fas-ø Chamfer ø	ø D2*						GH-S-O-
6 - 7	6	7.3	7.4	7.3	7.4	1.5	4	5.8	95	41	1762
7 - 8	7	8.3	8.4	8.0	8.1	1.5	4	6.5	95	41	1765
8 - 10	8	11.0	11.2	10.0	10.2	2	6	7.5	110	50	1768
10 - 12	10	13.0	13.2	12.0	12.2	2	6	9.5	110	50.5	1771
12 - 14	12	16.0	16.2	14.6	14.8	3	8	11	120	59	1774
14 - 16	14	18.0	18.2	16.6	16.8	3	8	13	120	59	1778
16 - 18	16	20.0	20.2	18.6	18.8	3	8	15	130	59	1781

\* Im Werk eingestellter D2 darf nicht verstellt werden

\*\* Erreichbare Fasengröße ist abhängig von Material, Messerkraft und Vorschub; ca. 0.1-0.6mm

Messer zu diesen GH-S Werkzeugen finden Sie auf den Seiten 17-18

\* Preset dia. D2 must not be changed

\*\* Attainable chamfer size depends on material, blade force and feed rate; approx. 0.1-0.6mm

Blades for these GH-S tools please find on pages 17-18

**8.5.2 GH-S Senkwerkzeuge 6-18, ohne Messer, mit zyl. Schaft lang**  
**GH-S Chamfering Tools 6-18, w/o blades, with cyl. shank extended**

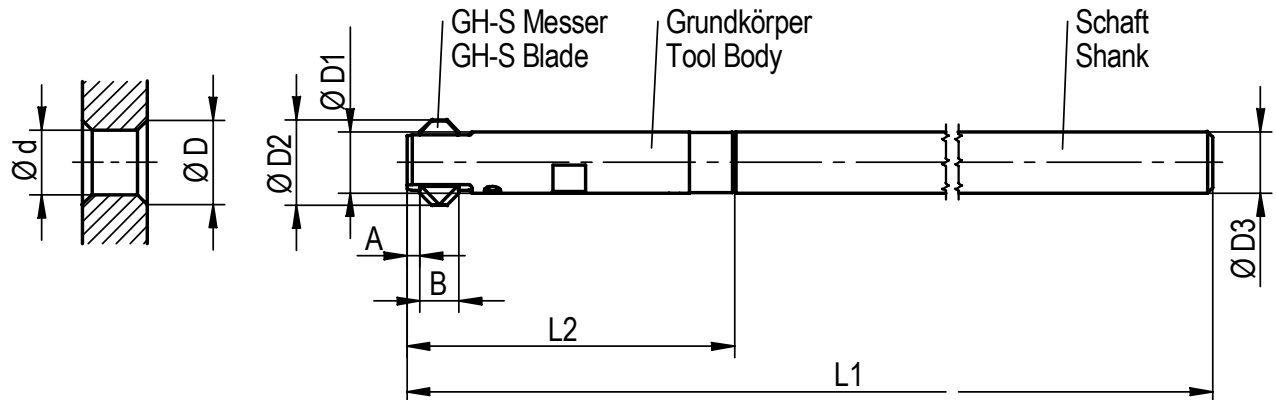

Werkzeug- bezeichnung (Bohrungs- bereich)	min. Bohrø	Fasbereich bei Faswinkel 90°		Fasbereich bei Faswinkel 60°		A	B	Ø D1	Ø D3	L1	L2	Best. Nr.
	min. boreø	Chamfer range for chamfer 90°		Chamfer range for chamfer 60°								Order No.
GH-S	ø d	D max.** Fas-ø Chamfer ø	ø D2*	D max.** Fas-ø Chamfer ø	ø D2*							GH-S-O-
<b>6 - 7</b>	6	7.3	7.4	7.3	7.4	1.5	4	5.8	5.8	200	41	1763
<b>7 - 8</b>	7	8.3	8.4	8.0	8.1	1.5	4	6.5	6	200	41	1766
<b>8 - 10</b>	8	11.0	11.2	10.0	10.2	2	6	7.5	7.5	200	50	1769
<b>10 - 12</b>	10	13.0	13.2	12.0	12.2	2	6	9.5	9.5	250	50.5	1772
<b>12 - 14</b>	12	16.0	16.2	14.6	14.8	3	8	11	10	250	59	1775
<b>14 - 16</b>	14	18.0	18.2	16.6	16.8	3	8	13	12	250	59	1779
<b>16 - 18</b>	16	20.0	20.2	18.6	18.8	3	8	15	15	250	59	1782

\* Im Werk eingestellter D2 darf nicht verstellt werden  
 \*\* Erreichbare Fasengröße ist abhängig von Material, Messerkraft und Vorschub; ca. 0.1-0.6mm  
 Messer zu diesen GH-S Werkzeugen finden Sie auf den Seiten 17-18

\* Preset dia. D2 must not be changed  
 \*\* Attainable chamfer size depends on material, blade force and feed rate; approx. 0.1-0.6mm  
 Blades for these GH-S tools please find on pages 17-18

### 8.5.3 GH-S Senkwerkzeuge 6-18, ohne Messer, mit MK Schaft GH-S Chamfering Tools 6-18, w/o blades, with MT shank

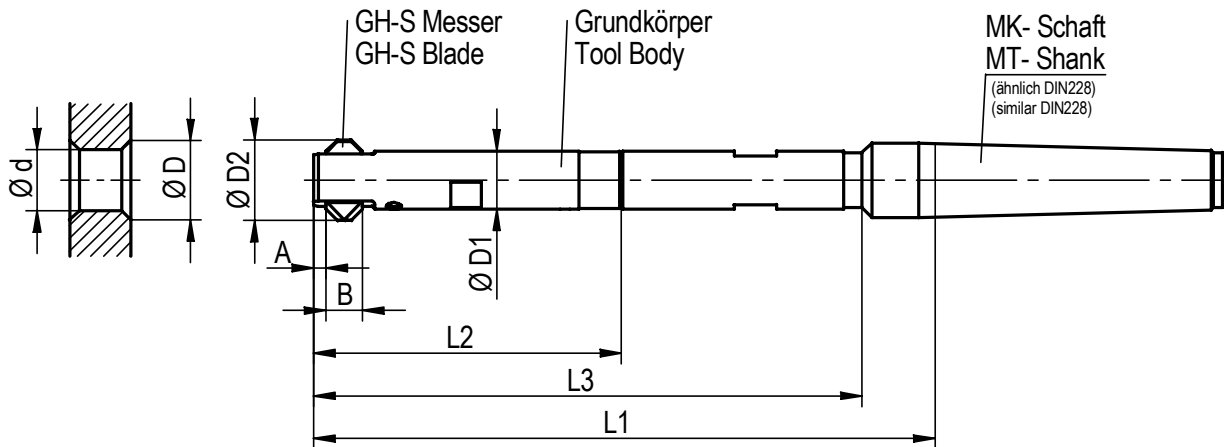

Werkzeug- bezeichnung (Bohrungs- bereich) <b>Tool description (bore range)</b>	min. Bohrø	Fasbereich bei Faswinkel 90°		Fasbereich bei Faswinkel 60°		A	B	ø D1 (L1)	L2 (L3)	Schaft MK	Best. Nr.
	min. boreø	Chamfer range for chamfer 90°		Chamfer range for chamfer 60°						Shank MT	Order No.
<b>GH-S</b>	ø d	D max.** Fas-ø Chamfer ø	ø D2*	D max.** Fas-ø Chamfer ø	ø D2*						GH-S-O-
<b>6 - 7</b>	6	7.3	7.4	7.3	7.4	1.5	4	5.8 (82)	41 (70)	1	1764
<b>7 - 8</b>	7	8.3	8.4	8.0	8.1	1.5	4	6.5 (82)	41 (70)	1	1767
<b>8 - 10</b>	8	11.0	11.2	10.0	10.2	2	6	7.5 (102)	50 (90)	1	1770
<b>10 - 12</b>	10	13.0	13.2	12.0	12.2	2	6	9.5 (102)	50.5 (90)	1	1773
<b>12 - 14</b>	12	16.0	16.2	14.6	14.8	3	8	11 (114)	59 (100)	1	1776
<b>12 - 14</b>	12	16.0	16.2	14.6	14.8	3	8	11 (114)	59 (100)	2	1777
<b>14 - 16</b>	14	18.0	18.2	16.6	16.8	3	8	13 (114)	59 (100)	2	1780
<b>16 - 18</b>	16	20.0	20.2	18.6	18.8	3	8	15 (114)	59 (100)	2	1783

\* Im Werk eingestellter D2 darf nicht verstellt werden

\*\* Erreichbare Fasengröße ist abhängig von Material, Messerkraft und Vorschub; ca. 0.1-0.6mm

Messer zu diesen GH-S Werkzeugen finden Sie auf den Seiten 17-18

\* Preset dia. D2 must not be changed

\*\* Attainable chamfer size depends on material, blade force and feed rate; approx. 0.1-0.6mm

Blades for these GH-S tools please find on pages 17-18

## 9 Messertypen für GH-S / Blades for GH-S

### 9.1 Messer für GH-S 4-22, vor- und rückwärts schneidend Blades for GH-S 4-22, forward and backward cutting

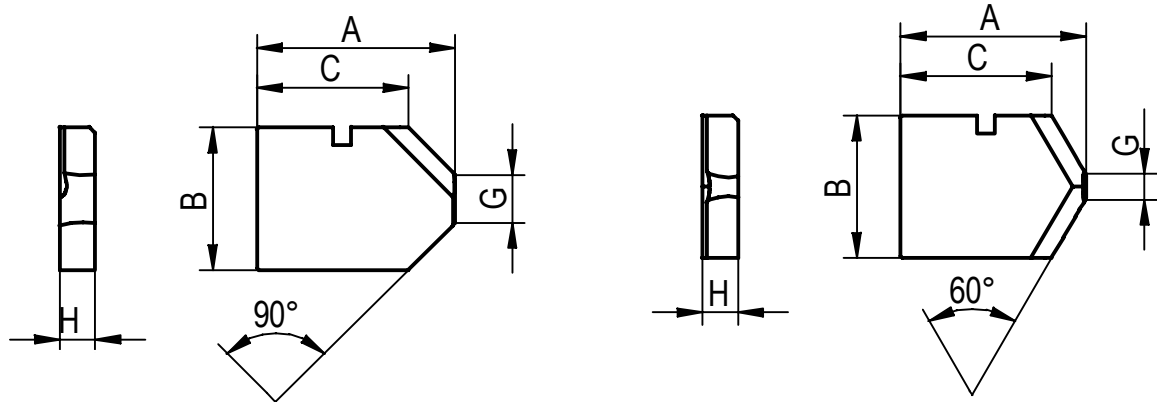

Messer- bezeichnung Blade description  GH - S	Fas- winkel chamfer angle	Bestellnummern für GH-S Messer vor- und rückwärts schneidend Order numbers for GH-S blades forward and backward cutting				Abmessungen Dimensions				
		HSS-E	HM	HSS-E-TIN	HM-TIN	A	B	C	G	H
		HSS-E GH-S-M-	Carbide GH-S-M-	HSS-E-TIN GH-S-M-	Carbide-TIN GH-S-M-					
4 - 4.5	90°	0001	1001	0801	1801	3.8	3.2	3.1	1.8	1
	60°	0600	1600	0900	1900	3.8			1.0	
4.5 - 5	90°	0002	1002	0802	1802	4.3	3.2	3.4	1.4	1
	60°	0601	1601	0901	1901	4.1			1.0	
5 - 5.5	90°	0003	1003	0803	1803	4.7	3.2	3.8	1.4	1
	60°	0602	1602	0902	1902	4.5			1.0	
5.5 - 6	90°	0004	1004	0804	1804	5.1	3.2	4.2	1.4	1
	60°	0603	1603	0903	1903	4.8			1.0	
6 - 7	90°	0005	1005	0805	1805	5.8	4	5.0	2.4	1.25
	60°	0604	1604	0904	1904	5.8			1.2	
7 - 8	90°	0006	1006	0806	1806	6.3	4	5.4	2.1	1.25
	60°	0605	1605	0905	1905	6.2			1.2	
8 - 10	90°	0007	1007	0807	1807	7.6	6	5.8	2.3	1.5
	60°	0606	1606	0906	1906	7.1			1.3	
10 - 12	90°	0008	1008	0808	1808	9.3	6	7.4	2.3	1.5
	60°	0607	1607	0907	1907	8.8			1.3	
12 - 14	90°	0009	1009	0809	1809	11.1	8	8.5	2.8	2
	60°	0608	1608	0908	1908	10.4			1.4	
14 - 16	90°	0010	1010	0810	1810	12.6	8	10.0	2.8	3
	60°	0609	1609	0909	1909	11.9			1.4	
16 - 18	90°	0011	1011	0811	1811	14.1	8	11.5	2.8	3
	60°	0610	1610	0910	1910	13.4			1.4	
18 - 20	90°	0012	1012	0812	1812	15.6	8	12.9	2.6	4
	60°	0611	1611	0911	1911	14.8			1.4	
20 - 22	90°	0013	1013	0813	1813	17.2	8	14.5	2.6	4
	60°	0612	1612	0912	1912	16.4			1.4	

## 9.2 Messer für GH-S 4-22, nur rückwärts schneidend Blades for GH-S 4-22, backward cutting only

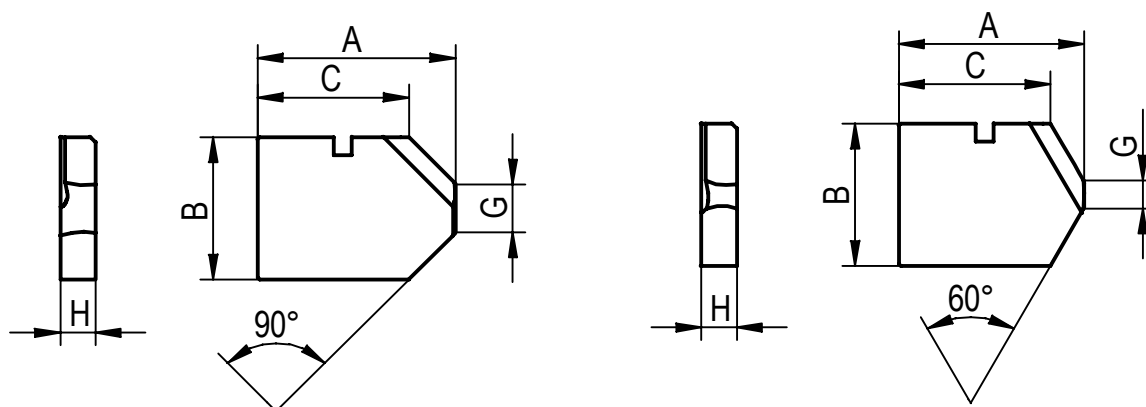

Messer- bezeichnung Blade description	Fas- winkel chamfer angle	Bestellnummern für GH-S Messer nur rückwärts schneidend				Abmessungen				
		Order numbers for GH-S blades backward cutting only				Dimensions				
		HSS-E GH-S-M-	HM Carbide GH-S-M-	HSS-E-TIN GH-S-M-	HM-TIN Carbide-TIN GH-S-M-	A	B	C	G	H
4 - 4.5	90°	2001	2201	2301	2401	3.8	3.2	3.1	1.8	1
	60°	2500	2600	2700	2800	3.8			1.0	
4.5 - 5	90°	2002	2202	2302	2402	4.3	3.2	3.4	1.4	1
	60°	2501	2601	2701	2801	4.1			1.0	
5 - 5.5	90°	2003	2203	2303	2403	4.7	3.2	3.8	1.4	1
	60°	2502	2602	2702	2802	4.5			1.0	
5.5 - 6	90°	2004	2204	2304	2404	5.1	3.2	4.2	1.4	1
	60°	2503	2603	2703	2803	4.8			1.0	
6 - 7	90°	2005	2205	2305	2405	5.8	4	5.0	2.4	1.25
	60°	2504	2604	2704	2804	5.8			1.2	
7 - 8	90°	2006	2206	2306	2406	6.3	4	5.4	2.1	1.25
	60°	2505	2605	2705	2805	6.2			1.2	
8 - 10	90°	2007	2207	2307	2407	7.6	6	5.8	2.3	1.5
	60°	2506	2606	2706	2806	7.1			1.3	
10 - 12	90°	2008	2208	2308	2408	9.3	6	7.4	2.3	1.5
	60°	2507	2607	2707	2807	8.8			1.3	
12 - 14	90°	2009	2209	2309	2409	11.1	8	8.5	2.8	2
	60°	2508	2608	2708	2808	10.4			1.4	
14 - 16	90°	2010	2210	2310	2410	12.6	8	10.0	2.8	3
	60°	2509	2609	2709	2809	11.9			1.4	
16 - 18	90°	2011	2211	2311	2411	14.1	8	11.5	2.8	3
	60°	2510	2610	2710	2810	13.4			1.4	
18 - 20	90°	2012	2212	2312	2412	15.6	8	12.9	2.6	4
	60°	2511	2611	2711	2811	14.8			1.4	
20 - 22	90°	2013	2213	2313	2413	17.2	8	14.5	2.6	4
	60°	2512	2612	2712	2812	16.4			1.4	

### 9.3 Messer für GH-S 22-100, vor- und rückwärts schneidend Blades for GH-S 22-100, forward and backward cutting

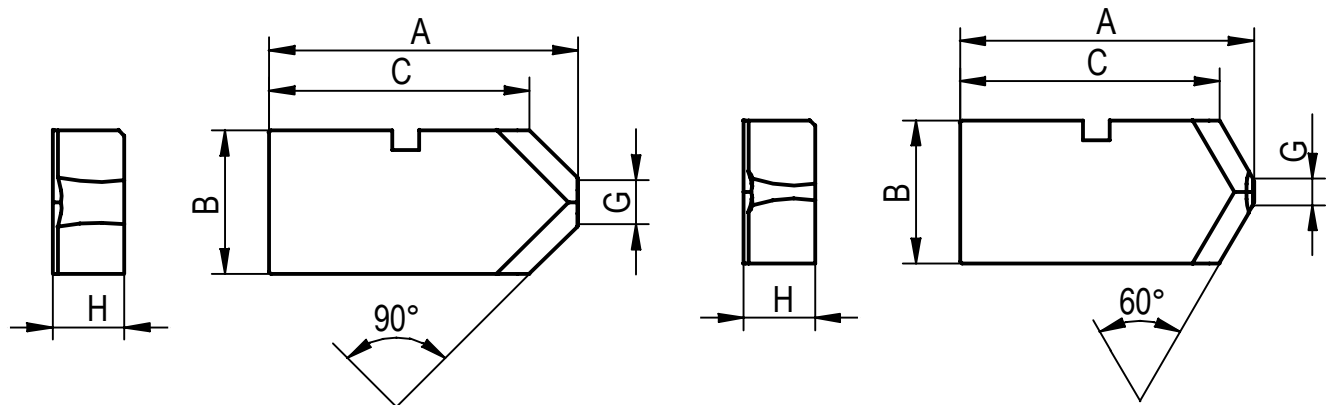

Messer- bezeichnung Blade description	Fas- winkel chamfer angle	Bestellnummern für GH-S Messer vor- und rückwärts schneidend Order numbers for GH-S blades forward and backward cutting				Abmessungen Dimensions				
		HSS-E GH-S-M-	HM Carbide GH-S-M-	HSS-E-TIN GH-S-M-	HM-TIN Carbide-TIN GH-S-M-	A	B	C	G	H
22 - 25	90°	0016	1014	0816	1814	19.1	9	16.0	2.8	5
	60°	0613	1613	0913	1913	18.2			1.4	
25 - 28	90°	0017	1015	0817	1815	20.6	9	17.5	2.8	5
	60°	0614	1614	0914	1914	19.7			1.4	
28 - 31	90°	0018	1016	0818	1816	24.2	10	20.7	3.0	6
	60°	0615	1615	0915	1915	23.2			1.3	
31 - 34	90°	0019	1017	0819	1817	25.7	10	22.2	3.0	6
	60°	0616	1616	0916	1916	24.7			1.3	
34 - 38	90°	0020	1018	0820	1818	28.2	10	24.5	2.6	6
	60°	0617	1617	0917	1917	27.0			1.3	
38 - 42	90°	0021	1019	0821	1819	32.2	10	28.5	2.6	6
	60°	0618	1618	0918	1918	31.1			1.3	
42 - 48	90°	0022	1020	0822	1820	38.3	16	32.0	3.4	9
48 - 54	90°	0023	1021	0823	1821	44.3	16	38.0	3.4	9
54 - 62	90°	0024	1022	0824	1822	50.2	20	42.0	4.5	12
62 - 70	90°	0025	1023	0825	1823	58.3	20	50.0	3.5	12
70 - 80	90°	0026	1024	0826	1824	65.3	24	55.0	3.5	12
80 - 90	90°	0028	1025	0828	1825	75.2	24	65.0	3.6	12
90 - 100	90°	0029	1026	0829	1826	85.2	24	75.0	3.5	12

## 9.4 Messer für GH-S 22-100, nur rückwärts schneidend Blades for GH-S 22-100, backward cutting only

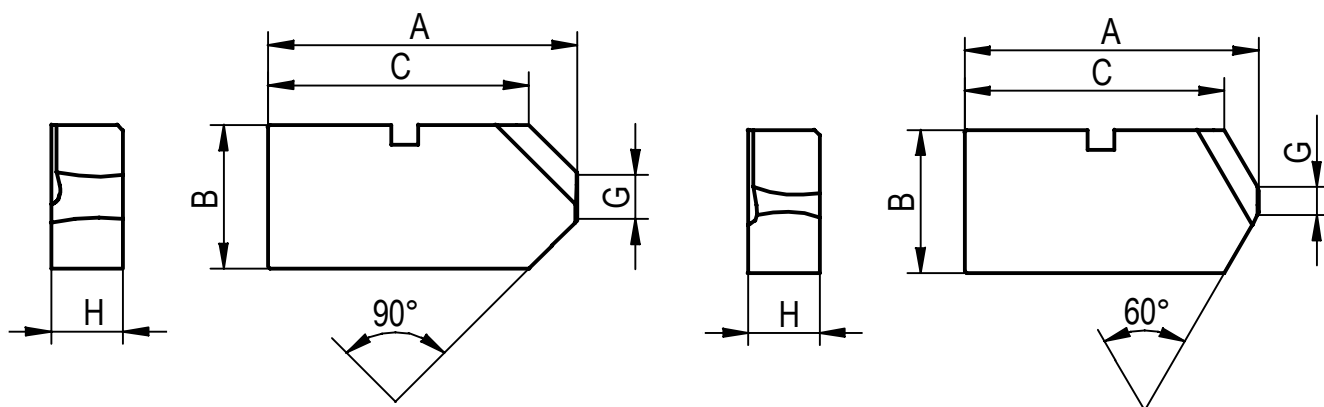

Messer- bezeichnung Blade description	Fas- winkel chamfer angle	Bestellnummern für GH-S Messer nur rückwärts schneidend				Abmessungen				
		Order numbers for GH-S blades backward cutting only				Dimensions				
		HSS-E HSS-E GH-S-M-	HM Carbide GH-S-M-	HSS-E-TIN HSS-E-TIN GH-S-M-	HM-TIN Carbide-TIN GH-S-M-	A	B	C	G	H
22 - 25	90°	2016	2214	2316	2414	19.1	9	16.0	2.8	5
	60°	2513	2613	2713	2813	18.2			1.4	
25 - 28	90°	2017	2215	2317	2415	20.6	9	17.5	2.8	5
	60°	2514	2614	2714	2814	19.7			1.4	
28 - 31	90°	2018	2216	2318	2416	24.2	10	20.7	3.0	6
	60°	2515	2615	2715	2815	23.2			1.3	
31 - 34	90°	2019	2217	2319	2417	25.7	10	22.2	3.0	6
	60°	2516	2616	2716	2816	24.7			1.3	
34 - 38	90°	2020	2218	2320	2418	28.2	10	24.5	2.6	6
	60°	2517	2617	2717	2817	27.0			1.3	
38 - 42	90°	2021	2219	2321	2419	32.2	10	28.5	2.6	6
	60°	2518	2618	2718	2818	31.1			1.3	
42 - 48	90°	2022	2220	2322	2420	38.3	16	32.0	3.4	9
48 - 54	90°	2023	2221	2323	2421	44.3	16	38.0	3.4	9
54 - 62	90°	2024	2222	2324	2422	50.2	20	42.0	4.5	12
62 - 70	90°	2025	2223	2325	2423	58.3	20	50.0	3.5	12
70 - 80	90°	2026	2224	2326	2424	65.3	24	55.0	3.5	12
80 - 90	90°	2028	2225	2328	2425	75.2	24	65.0	3.6	12
90 - 100	90°	2029	2226	2329	2426	85.2	24	75.0	3.5	12

# 10 Schäfte für GH-S / Shanks for GH-S

## 10.1 Schäfte für GH-S Senkwerkzeuge 4-10 Shanks for GH-S Chamfering Tools 4-10

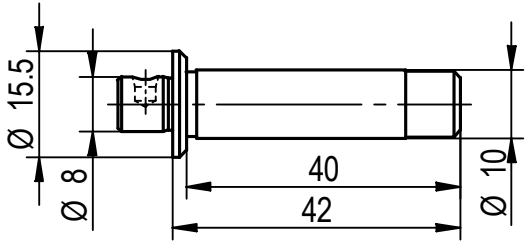
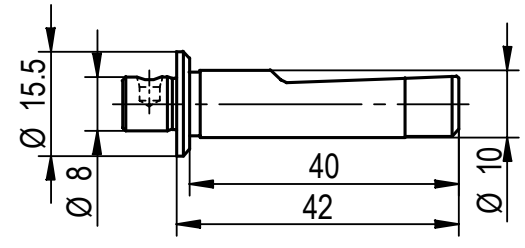
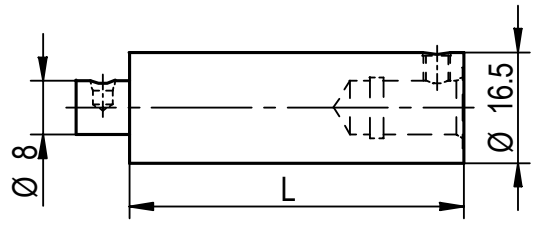
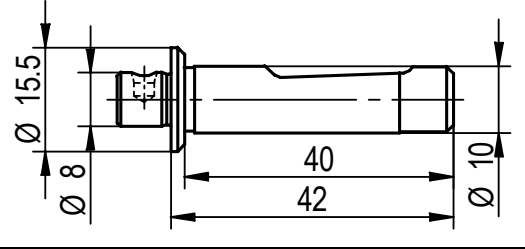
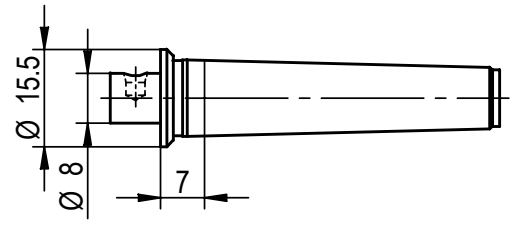
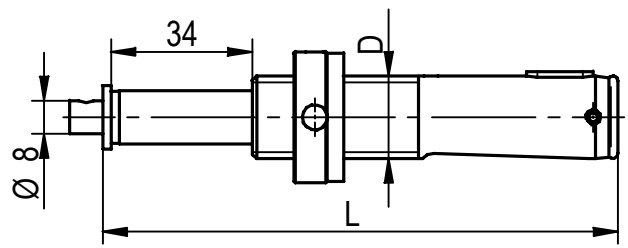
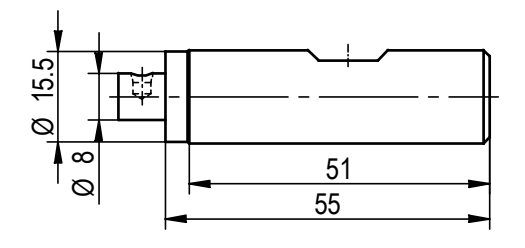
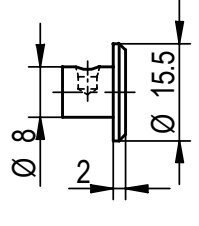
Schafttyp Shank type	Bestell-Nr. Order No.	Schafttyp Shank type	Bestell-Nr. Order No.												
zylindrisch $\varnothing 10$ cylindrical $\varnothing 10$ 	<b>GH-S-S-0001</b>	Verlängerung    Extension	Bestell-Nr. Order No.												
		L													
		50mm	<b>GH-S-R-0076</b>												
		100mm	<b>GH-S-R-0077</b>												
		150mm	<b>GH-S-R-0078</b>												
zylindrisch $\varnothing 10$ cylindrical $\varnothing 10$ ähnlich, similar DIN 1835 E 10 	<b>GH-S-S-0170</b>														
zylindrisch $\varnothing 10$ cylindrical $\varnothing 10$ ähnlich, similar DIN 6535 HE 10 	<b>GH-S-S-0176</b>	Auffahr-    Safety Crash sicherung mit    Holder with Klemmutter    Clamping Nut <table border="1"> <thead> <tr> <th>L</th> <th>D</th> <th>Bestell-Nr. Order No.</th> </tr> </thead> <tbody> <tr> <td>124mm</td> <td>Tr 20x2</td> <td><b>GH-A-O-0008</b></td> </tr> <tr> <td>131mm</td> <td>Tr 25x2</td> <td><b>GH-A-O-0010</b></td> </tr> <tr> <td>131mm</td> <td>Tr 28x2</td> <td><b>GH-A-O-0017</b></td> </tr> </tbody> </table>	L	D	Bestell-Nr. Order No.	124mm	Tr 20x2	<b>GH-A-O-0008</b>	131mm	Tr 25x2	<b>GH-A-O-0010</b>	131mm	Tr 28x2	<b>GH-A-O-0017</b>	
L	D	Bestell-Nr. Order No.													
124mm	Tr 20x2	<b>GH-A-O-0008</b>													
131mm	Tr 25x2	<b>GH-A-O-0010</b>													
131mm	Tr 28x2	<b>GH-A-O-0017</b>													
MK 1    MT 1 ähnlich, similar DIN 228, Form A 	<b>GH-S-S-0002</b>														
Austreibblappen, siehe Seite 36    Tang, see on page 36															
Weldon 16    Weldon 16 	<b>GH-S-S-0036</b>	Abschlusszapfen    End Plug 	<b>GH-S-S-0090</b>												
		Nötig, wenn Werkzeug am Grundkörper in Spannzange gespannt wird    Required, if tool clamped into collet at tool body													
zylindrisch $\varnothing \frac{3}{8}$ "    cylindrical $\varnothing \frac{3}{8}$ " 	<b>GH-S-S-0155</b>														

# Schäfte für GH-S Senkwerkzeuge 4-10

## Shanks for GH-S Chamfering Tools 4-10

Schaffttyp Shank type		Bestell-Nr. Order No.	Schaffttyp Shank type		Bestell-Nr. Order No.
Stellhülse* Tr 16 x 1.5 ähnlich, similar DIN 6327	Automotive Shank* Tr 16 x 1.5	<b>GH-S-S-0101</b>	ABS 25	ABS 25	<b>GH-S-A-0014</b>
Stellhülse* Tr 20 x 2 ähnlich, similar DIN 6327	Automotive Shank* Tr 20 x 2	<b>GH-S-S-0111</b>	ABS 32	ABS 32	<b>GH-S-A-0015</b>
Stellhülse* Tr 25 x 2 ähnlich, similar DIN 6327	Automotive Shank* Tr 25 x 2	<b>GH-S-S-0107</b>	ABS 40	ABS 40	<b>GH-S-A-0010</b>
Stellhülse* Tr 28 x 2 ähnlich, similar DIN 6327	Automotive Shank* Tr 28 x 2	<b>GH-S-S-0106</b>	ABS 50	ABS 50	<b>GH-S-A-0011</b>

\* alle Stellhülenschäfte ohne Klemmutter.  
Klemmuttern, siehe Seite 36

\* all automotive shanks without clamping nut.  
Clamping nut, see page 36

## 10.2 Schäfte für GH-S Senkwerkzeuge 10-22 Shanks for GH-S Chamfering Tools 10-22

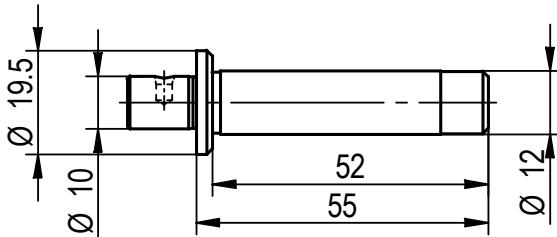
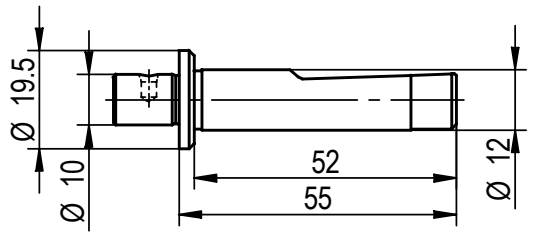
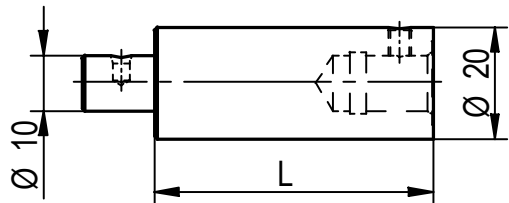
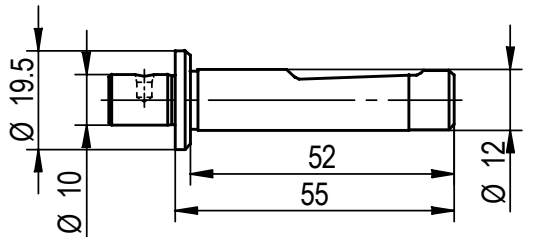
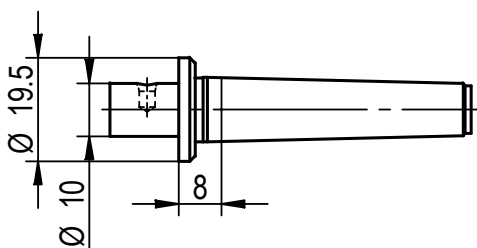
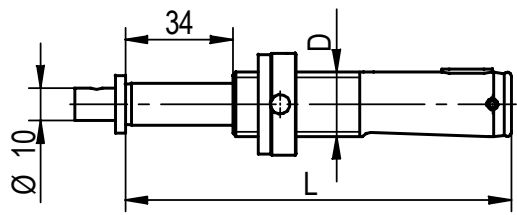
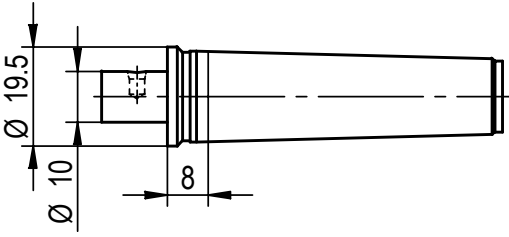
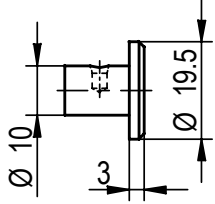
Schafttyp Shank type	Bestell-Nr. Order No.	Schafttyp Shank type	Bestell-Nr. Order No.
zylindrisch $\varnothing 12$ cylindrical $\varnothing 12$ <b>GH-S-S-0013</b> 	<b>GH-S-S-0013</b>	Verlängerung Extension L 50mm 100mm 150mm Bestell-Nr. Order No. <b>GH-S-R-0016</b> <b>GH-S-R-0017</b> <b>GH-S-R-0003</b>	
zylindrisch $\varnothing 12$ cylindrical $\varnothing 12$ ähnlich, similar DIN 1835 E 12 <b>GH-S-S-0171</b> 	<b>GH-S-S-0171</b>		
zylindrisch $\varnothing 12$ cylindrical $\varnothing 12$ ähnlich, similar DIN 6535 HE 12 <b>GH-S-S-0175</b> 	<b>GH-S-S-0175</b>	Auffahr- sicherung mit Klemmutter Safety Crash Holder with Clamping Nut Bestell-Nr. Order No. L D 125mm Tr 20x2 <b>GH-A-O-0009</b> 132mm Tr 25x2 <b>GH-A-O-0011</b> 132mm Tr 28x2 <b>GH-A-O-0016</b> 132mm Tr 1 $\frac{1}{16}$ "-12 <b>GH-A-O-0015</b> excl. Clamping Nut	
MK 1 MT 1 ähnlich, similar DIN 228, Form A <b>GH-S-S-0016</b> 	<b>GH-S-S-0016</b>		
MK 2 MT 2 ähnlich, similar DIN 228, Form A <b>GH-S-S-0017</b> 	<b>GH-S-S-0017</b>	Abschluss- zapfen End Plug <b>GH-S-S-0092</b> 	
zylindrisch $\varnothing 1\frac{1}{2}$ " cylindrical $\varnothing 1\frac{1}{2}$ " <b>GH-S-S-0156</b>	<b>GH-S-S-0156</b>	Nötig, wenn Werkzeug am Grundkörper in Spannzange gespannt wird Required, if tool clamped into collet at tool body	

# Schäfte für GH-S Senkwerkzeuge 10-22

## Shanks for GH-S Chamfering Tools 10-22

Schafttyp Shank type		Bestell-Nr. Order No.	Schafttyp Shank type		Bestell-Nr. Order No.
Stellhülse* Tr 16 x 1.5 ähnlich, similar DIN 6327	Automotive Shank* Tr 16 x 1.5	<b>GH-S-S-0103</b>	ABS 25	ABS 25	<b>GH-S-A-0012</b>
Stellhülse* Tr 20 x 2 ähnlich, similar DIN 6327	Automotive Shank* Tr 20 x 2	<b>GH-S-S-0110</b>	ABS 32	ABS 32	<b>GH-S-A-0013</b>
Stellhülse* Tr 25 x 2 ähnlich, similar DIN 6327	Automotive Shank* Tr 25 x 2	<b>GH-S-S-0108</b>	<b>GH-S-A-0017</b> 		
Stellhülse* Tr 28 x 2 ähnlich, similar DIN 6327	Automotive Shank* Tr 28 x 2	<b>GH-S-S-0105</b>	ABS 50	ABS 50	<b>GH-S-A-0017</b>
Weldon 16	Weldon 16	<b>GH-S-S-0034</b>	Weldon 20	Weldon 20	<b>GH-S-S-0037</b>

\* alle Stellhülenschäfte ohne Klemmutter  
Klemmuttern, siehe Seite 36

\* all automotive shanks without clamping nut  
Clamping nut, see page 36

### 10.3 Schäfte für GH-S Senkwerkzeuge 18-22 Shanks for GH-S Chamfering Tools 18-22

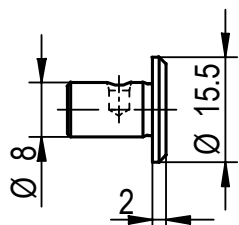
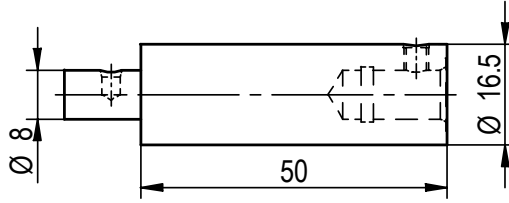
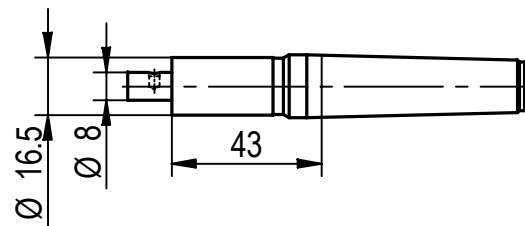
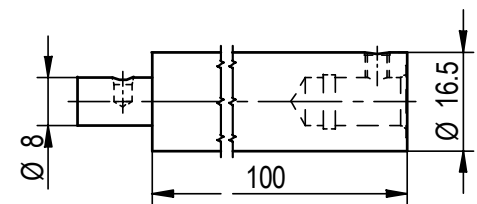
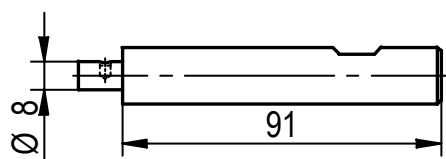
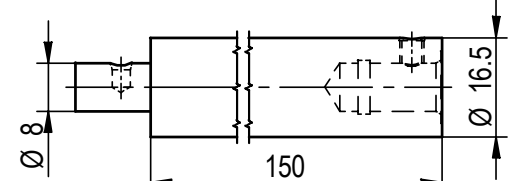
Schaffttyp Shank type		Bestell-Nr. Order No.	Schaffttyp Shank type		Bestell-Nr. Order No.
Abschlusszapfen End Plug	<b>GH-S-S-0091</b>		Verlängerung 50 mm Extension 50 mm	<b>GH-S-R-0012</b>	
Nötig, wenn Werkzeug am Grundkörper in Spannzange gespannt wird Required, if tool clamped into collet at tool body					
MK 2 ähnlich, similar DIN 228, Form A	MT 2 <b>GH-S-S-0032</b>		Verlängerung 100 mm Extension 100 mm	<b>GH-S-R-0013</b>	
Austreibblappen, siehe Seite 36 Tang, see on page 36					
Weldon 16	Weldon 16 <b>GH-S-S-0033</b>		Verlängerung 150 mm Extension 150 mm	<b>GH-S-R-0001</b>	

## 10.4 Schäfte für GH-S Senkwerkzeuge 22-28 Shanks for GH-S Chamfering Tools 22-28

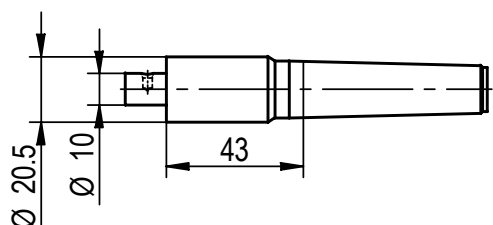
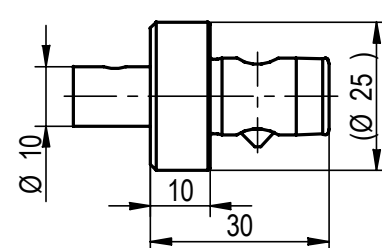
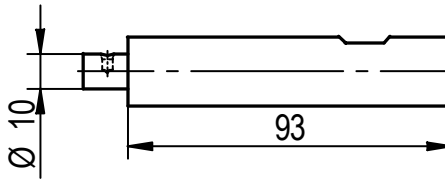
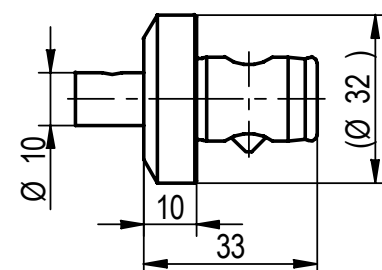
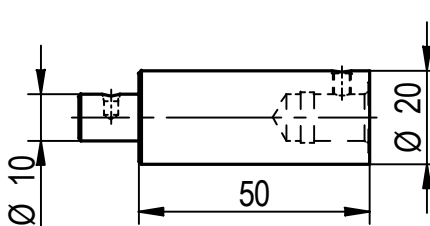
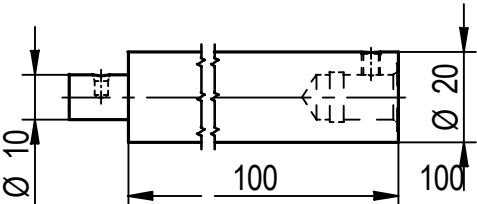
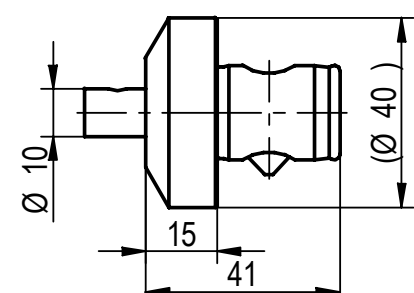
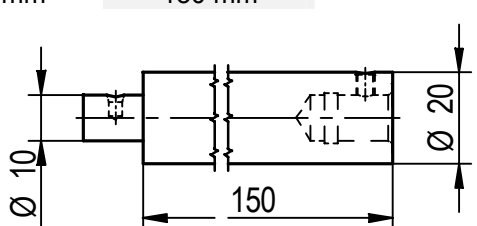
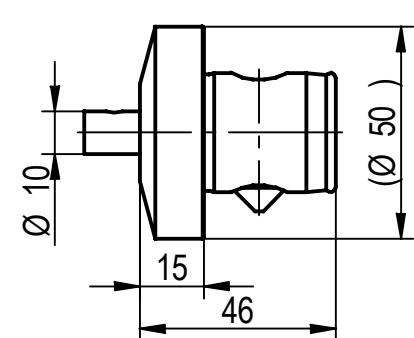
Schaffttyp Shank type		Bestell-Nr. Order No.	Schaffttyp Shank type		Bestell-Nr. Order No.
MK 2 ähnlich, similar DIN 228, Form A	MT 2	<b>GH-S-S-0038</b>	ABS 25	ABS 25	<b>GH-S-A-0012</b>
					
Austreibblappen, siehe Seite 36	Tang, see on page 36				
Weldon 20	Weldon 20	<b>GH-S-S-0037</b>	ABS 32	ABS 32	<b>GH-S-A-0013</b>
					
Verlängerung 50 mm	Extension 50 mm	<b>GH-S-R-0016</b>			
					
Verlängerung 100 mm	Extension 100 mm	<b>GH-S-R-0017</b>	ABS 40	ABS 40	<b>GH-S-A-0016</b>
					
Verlängerung 150 mm	Extension 150 mm	<b>GH-S-R-0003</b>	ABS 50	ABS 50	<b>GH-S-A-0017</b>
					

## 10.5 Schäfte für GH-S Senkwerkzeuge 28-34 Shanks for GH-S Chamfering Tools 28-34

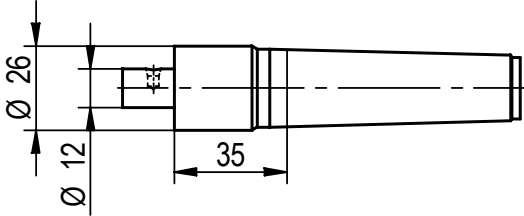
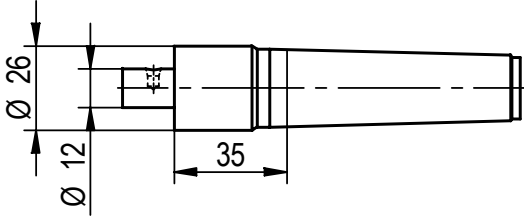
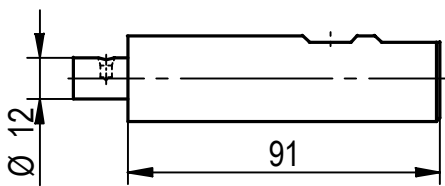
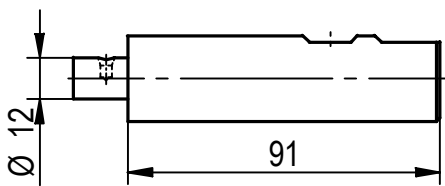
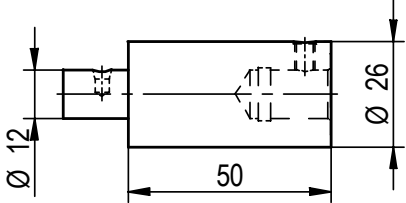
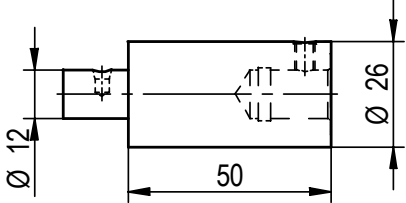
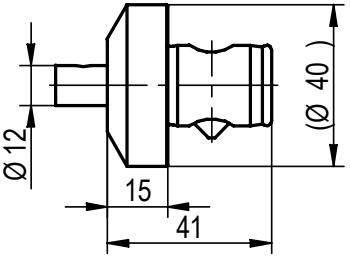
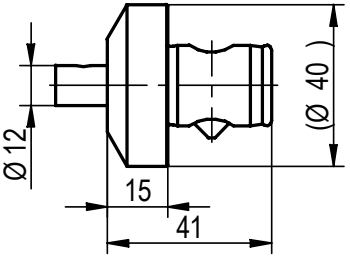
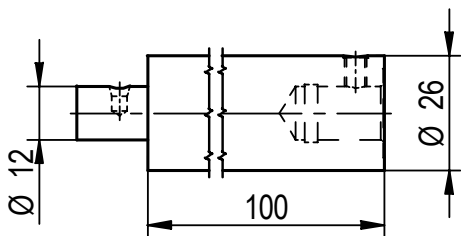
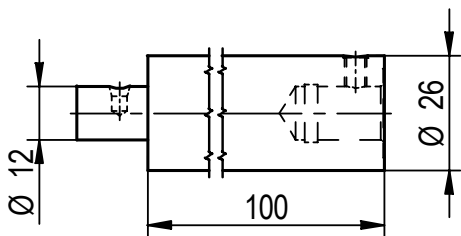
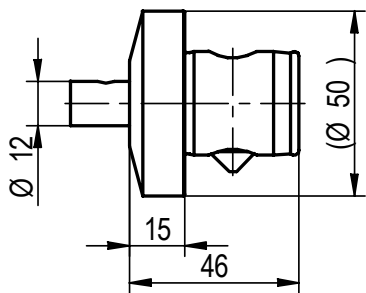
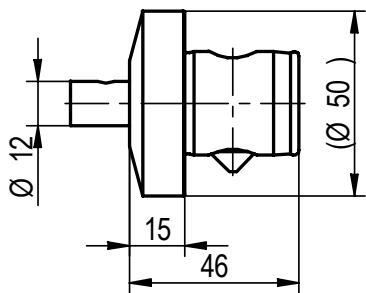
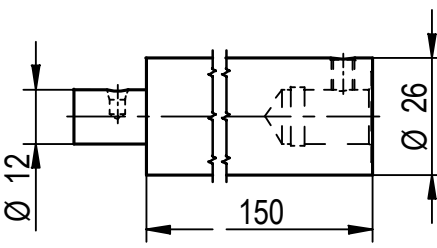
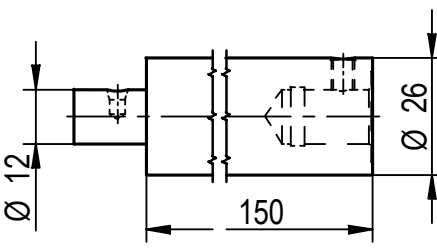
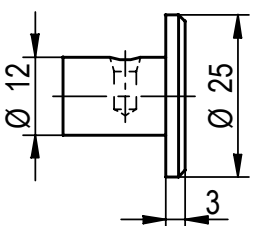
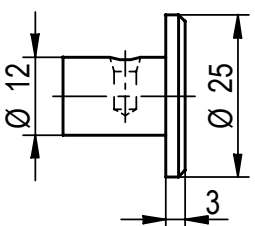
Schafttyp Shank type	Bestell-Nr. Order No.	Schafttyp Shank type	Bestell-Nr. Order No.
MK 3 ähnlich, similar DIN 228, Form A	MT 3 <b>GH-S-S-0043</b>	Weldon 25 Weldon 25	<b>GH-S-S-0042</b>
			
Austreibblappen, siehe Seite 36	Tang, see on page 36		
Verlängerung 50 mm	Extension 50 mm <b>GH-S-R-0020</b>	ABS 40 ABS 40	<b>GH-S-A-0036</b>
			
Verlängerung 100 mm	Extension 100 mm <b>GH-S-R-0021</b>	ABS 50 ABS 50	<b>GH-S-A-0029</b>
			
Verlängerung 150 mm	Extension 150 mm <b>GH-S-R-0005</b>	Abschluss- zapfen	End Plug <b>GH-S-S-0093</b>
			
		Nötig, wenn Werkzeug am Grundkörper in Spannzange gespannt wird	Required, if tool clamped into collet at tool body

## 10.6 Schäfte für GH-S Senkwerkzeuge 34-42 Shanks for GH-S Chamfering Tools 34-42

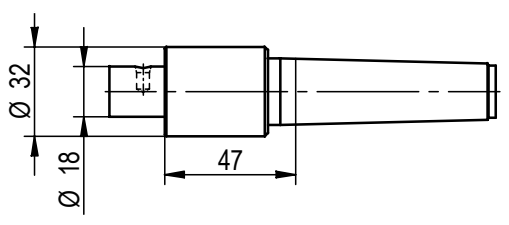
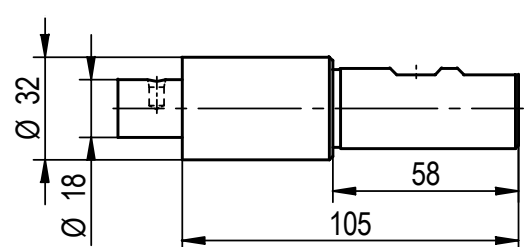
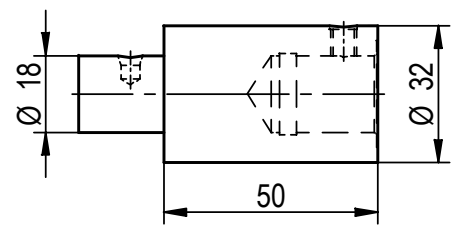
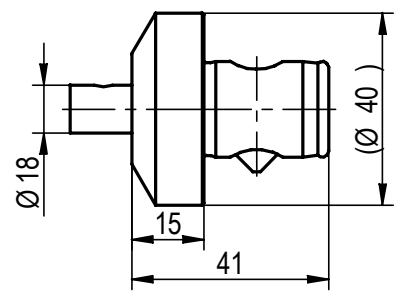
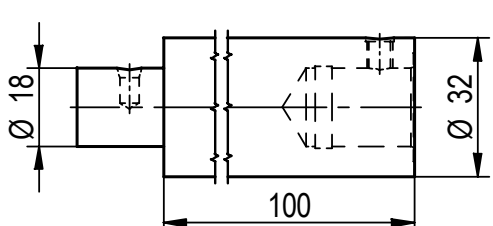
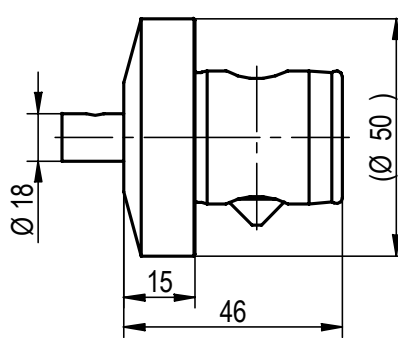
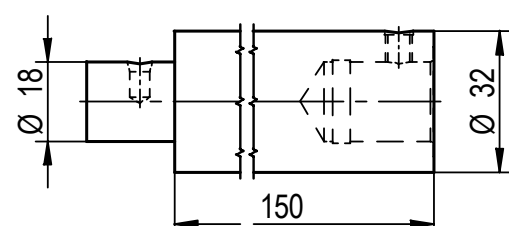
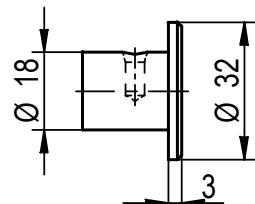
Schafttyp Shank type		Bestell-Nr. Order No.	Schafttyp Shank type		Bestell-Nr. Order No.
MK 3 ähnlich, similar DIN 228, Form A	MT 3	<b>GH-S-S-0049</b>	Weldon 25	Weldon 25	<b>GH-S-S-0048</b>
					
Austreibblappen, siehe Seite 36 Tang, see on page 36					
Verlängerung 50 mm	Extension 50 mm	<b>GH-S-R-0024</b>	ABS 40	ABS 40	<b>GH-S-A-0037</b>
					
Verlängerung 100 mm	Extension 100 mm	<b>GH-S-R-0025</b>	ABS 50	ABS 50	<b>GH-S-A-0038</b>
					
150 mm	Extension 150 mm	<b>GH-S-R-0007</b>	Abschlusszapfen End Plug	End Plug	<b>GH-S-S-0094</b>
					
			Nötig, wenn Werkzeug am Grundkörper in Spannzange gespannt wird Required, if tool clamped into collet at tool body		

## 10.7 Schäfte für GH-S Senkwerkzeuge 42-70 Shanks for GH-S Chamfering Tools 42-70

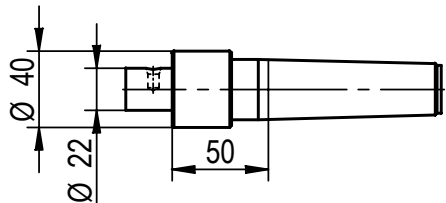
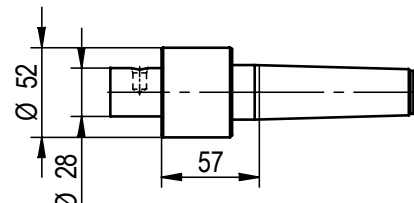
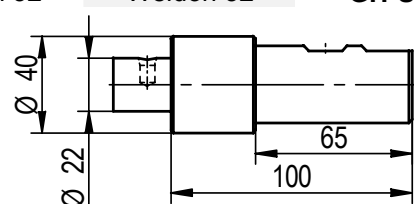
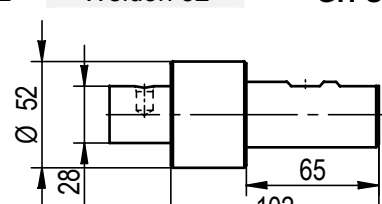
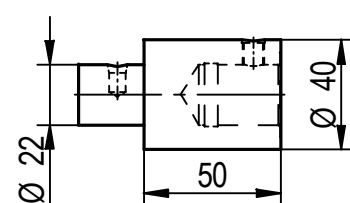
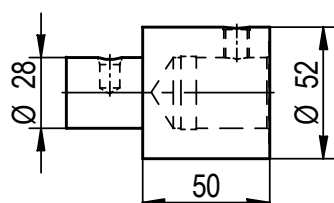
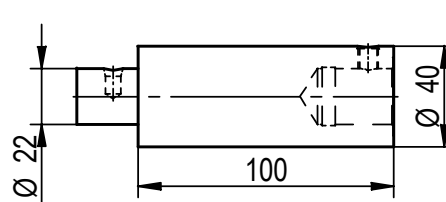
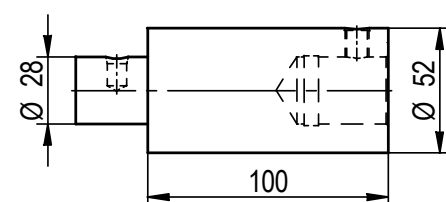
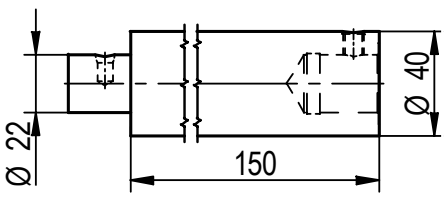
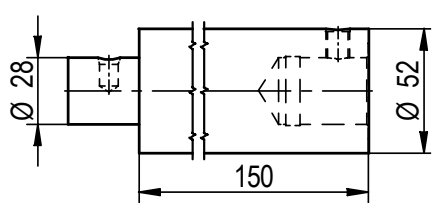
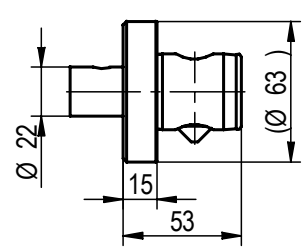
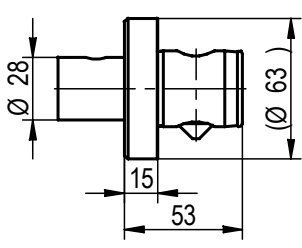
Schaffttyp 42-54 Shank type 42-54		Bestell-Nr. Order No.	Schaffttyp 54-70 Shank type 54-70		Bestell-Nr. Order No.
MK 4 ähnlich, similar DIN 228, Form A	MT 4	<b>GH-S-S-0052</b>	MK 4 ähnlich, similar DIN 228, Form A	MT 4	<b>GH-S-S-0055</b>
					
Austreibblappen, siehe Seite 36		Tang, see on page 36	Austreibblappen, siehe Seite 36		Tang, see on page 36
Weldon 32	Weldon 32	<b>GH-S-S-0179</b>	Weldon 32	Weldon 32	<b>GH-S-S-0177</b>
					
Verlängerung 50 mm	Extension 50 mm	<b>GH-S-R-0028</b>	Verlängerung 50 mm	Extension 50 mm	<b>GH-S-R-0032</b>
					
Verlängerung 100 mm	Extension 100 mm	<b>GH-S-R-0029</b>	Verlängerung 100 mm	Extension 100 mm	<b>GH-S-R-0033</b>
					
Verlängerung 150 mm	Extension 150 mm	<b>GH-S-R-0009</b>	Verlängerung 150 mm	Extension 150 mm	<b>GH-S-R-0011</b>
					
ABS 63	ABS 63	<b>GH-S-A-0040</b>	ABS 63	ABS 63	<b>GH-S-A-0019</b>
					

## 10.8 Schäfte für GH-S Senkwerkzeuge 70-100 Shanks for GH-S Chamfering Tools 70-100

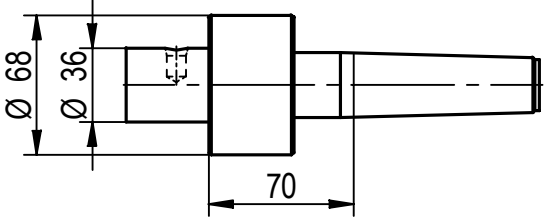
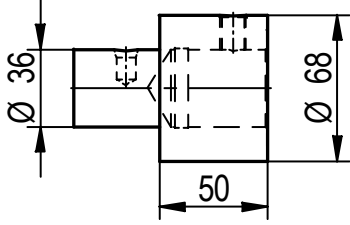
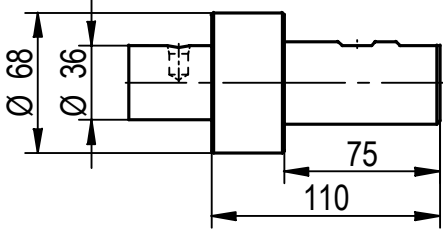
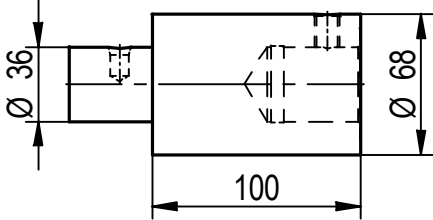
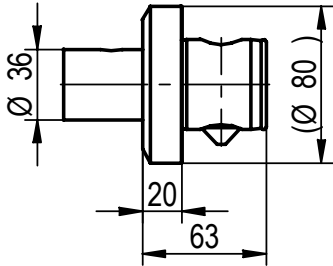
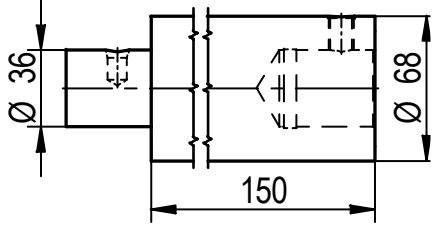
Schaffttyp Shank type		Bestell-Nr. Order No.	Schaffttyp Shank type		Bestell-Nr. Order No.
MK 4 ähnlich, similar DIN 228, Form A	MT 4	<b>GH-S-S-0060</b>	Verlängerung 50 mm	Extension 50 mm	<b>GH-S-R-0036</b>
					
Austreibblappen, siehe Seite 36	Tang, see on page 36				
Weldon 40	Weldon 40	<b>GH-S-S-0178</b>	Verlängerung 100 mm	Extension 100 mm	<b>GH-S-R-0037</b>
					
ABS 80	ABS 80	<b>GH-S-A-0042</b>	Verlängerung 150 mm	Extension 150 mm	<b>GH-S-R-0043</b>
					

# 11 Ersatzteile für GH-S / Spare parts for GH-S

## 11.1 Ersatzteile für GH-S Senkwerkzeuge 4-10 Spare parts for GH-S Chamfering Tools 4-10

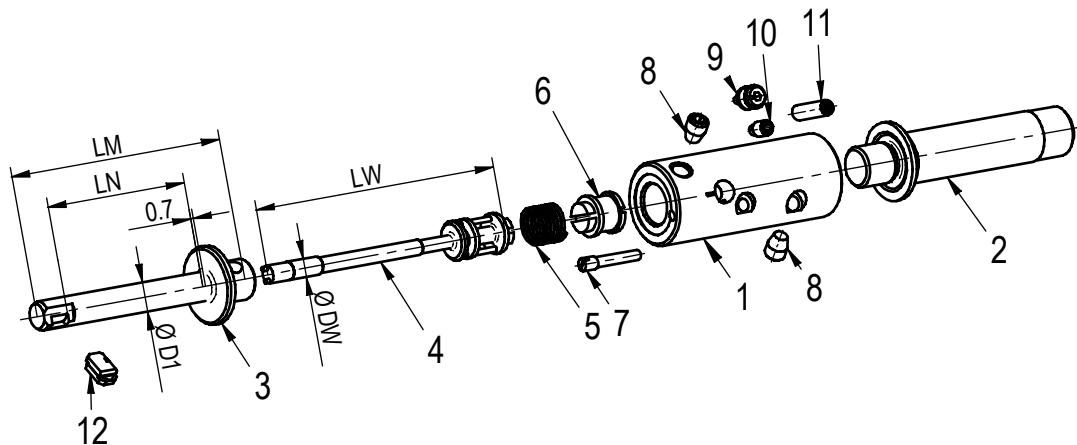

Pos.	Bezeichnung	Description	Bestell-Nr.	Order No.
1	Grundkörper Ø16.5 Grundkörper Ø16h6	Tool Body Ø16.5 Tool Body Ø16h6	GH-S-G-0001 GH-S-G-0217	
2	Schaft	Shank	siehe Seiten 21-22	see pages 21-22
3	Messergehäuse	Blade Housing	siehe Tabelle unten	see table below
4	Wippe	Blade Control	siehe Tabelle unten	see table below
5	Torsionsfeder	Torsion Spring	GH-S-T-0001	
6	Spannstück	Gear Wheel	GH-S-C-0001	
7	Fixierschraube	Positioning Screw	GH-S-X-0001	
8	Klemmschraube	Clamping Screw	GH-H-S-0201	
9	Exzenter	Eccentric Cam	GH-S-E-0001	
10	Einstellschraube	Set Screw	GH-H-S-0301	
11	Spannschraube	Tension Screw	GH-H-S-0101	
12	Messer	Blades	siehe Seiten 17-18	see pages 17-18

Werkzeugbezeichnung Tool description  GH-S	Pos. 3 Messergehäuse mit Standard D1 Blade Housing with standard D1				Pos. 4 Wippe Blade Control		
	LN	D1	LM	Bestell-Nr.	DW	LW	Bestell-Nr.
				Order No. GH-S-N-			Order No. GH-S-W-
<b>4 - 4.5/15</b>	15	3.8	30.5	0001	2.0	38.5	0002
<b>4 - 4.5/30</b>	30		45.5	0002	2.0	53.5	0003
<b>4 - 4.5/60</b>	60		75.5	0032	2.0	83.5	0027
<b>4.5 - 5/15</b>	15	4.3	30.5	0004	2.0	38.5	0002
<b>4.5 - 5/30</b>	30		45.5	0005	2.0	53.5	0003
<b>4.5 - 5/60</b>	60		75.5	0033	2.0	83.5	0027
<b>5 - 5.5/15</b>	15	4.8	30.5	0006	2.0	38.5	0002
<b>5 - 5.5/30</b>	30		45.5	0007	2.0	53.5	0003
<b>5 - 5.5/60</b>	60		75.5	0034	2.0	83.5	0027
<b>5.5 - 6/15</b>	15	5.3	30.5	0008	2.0	38.5	0002
<b>5.5 - 6/30</b>	30		45.5	0009	2.0	53.5	0003
<b>5.5 - 6/60</b>	60		75.5	0035	2.0	83.5	0027
<b>6 - 7/20</b>	20	5.8	36.3	0010	3.6	43.4	0504
<b>6 - 7/34</b>	34		50.3	0011	3.6	57.4	0505
<b>6 - 7/60</b>	60		76.3	0036	3.6	83.4	0528
<b>7 - 8/20</b>	20	6.5	36.3	0012	3.6	43.4	0504
<b>7 - 8/34</b>	34		50.3	0013	3.6	57.4	0505
<b>7 - 8/60</b>	60		76.3	0037	3.6	83.4	0528
<b>8 - 10/20</b>	20	7.5	38.3	0016	3.6	43.4	0504
<b>8 - 10/34</b>	34		52.3	0017	3.6	57.4	0505
<b>8 - 10/60</b>	60		78.3	0038	3.6	83.4	0528

## 11.2 Ersatzteile für GH-S Senkwerkzeuge 10-22 Spare parts for GH-S Chamfering Tools 10-22

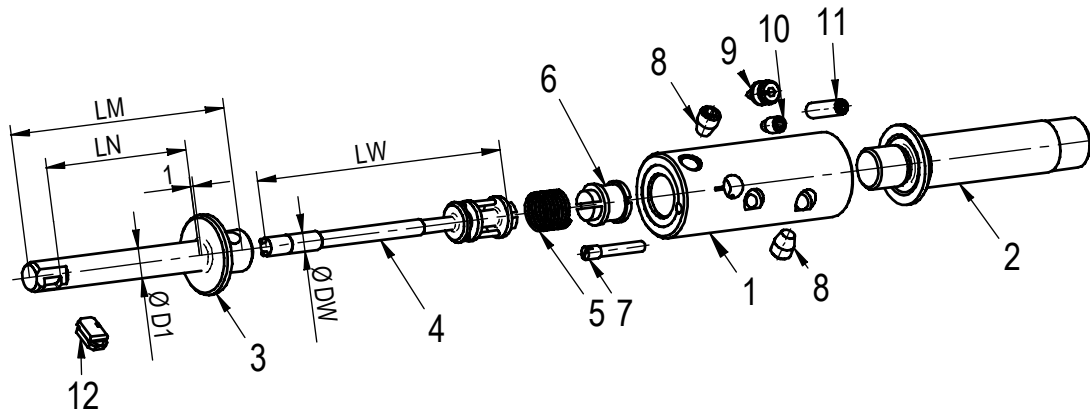

Pos.	Bezeichnung	Description	Bestell-Nr.	Order No.
1	Grundkörper 10-18 Grundkörper 18-22	Tool Body 10-18 Tool Body 18-22	GH-S-G-0011 GH-S-G-0013	
2	Schaft	Shank	siehe Seiten 23-24	see pages 23-24
3	Messergehäuse	Blade Housing	siehe Tabelle unten	see table below
4	Wippe	Blade Control	siehe Tabelle unten	see table below
5	Torsionsfeder	Torsion Spring	GH-S-T-0006	
6	Spannstück	Gear Wheel	GH-S-C-0008	
7	Fixierschraube	Positioning Screw	GH-S-X-0006	
8	Klemmschraube	Clamping Screw	GH-H-S-0201	
9	Exzenter	Eccentric Cam	GH-S-E-0003	
10	Einstellschraube	Set Screw	GH-H-S-0302	
11	Spannschraube	Tension Screw	GH-H-S-0102	
12	Messer	Blades	siehe Seiten 17-18	see pages 17-18

Werkzeugbezeichnung Tool description  GH-S	Pos. 3 Messergehäuse mit Standard D1 Blade Housing with standard D1				Pos. 4 Wippe Blade Control		
	LN	D1	LM	Bestell-Nr.	DW	LW	Bestell-Nr.
				Order No. GH-S-N-			Order No. GH-S-W-
10 - 12/30	30	9.5	56	0020	4.5	65.8	0508
10 - 12/60	60		86	0021	4.5	95.8	0509
10 - 12/100	100		126	0039	4.5	135.8	0529
12 - 14/30	30	11	56	0022	5.5	65.8	0511
12 - 14/60	60		86	0023	5.5	95.8	0512
12 - 14/100	100		126	0040	5.5	135.8	0530
14 - 16/30	30	13	58	0024	5.5	65.8	0511
14 - 16/60	60		88	0025	5.5	95.8	0512
14 - 16/100	100		128	0041	5.5	135.8	0530
16 - 18/30	30	15	58	0026	5.5	65.8	0511
16 - 18/60	60		88	0027	5.5	95.8	0512
16 - 18/100	100		128	0042	5.5	135.8	0530
18 - 20/30	30	16.5	58	0028	8.0	65.8	0520
18 - 20/60	60		88	0029	8.0	95.8	0521
18 - 20/100	100		128	0043	8.0	135.8	0531
20 - 22/30	30	18.5	58	0030	8.0	65.8	0520
20 - 22/60	60		88	0031	8.0	95.8	0521
20 - 22/100	100		128	0044	8.0	135.8	0531

für GH-S 10-18: Q = 10 mm  
für GH-S 18-22: Q = 12 mm

for GH-S 10-18: Q = 10 mm  
for GH-S 18-22: Q = 12 mm

## 11.3 Ersatzteile für GH-S Senkwerkzeuge 18-42 Spare parts for GH-S Chamfering Tools 18-42

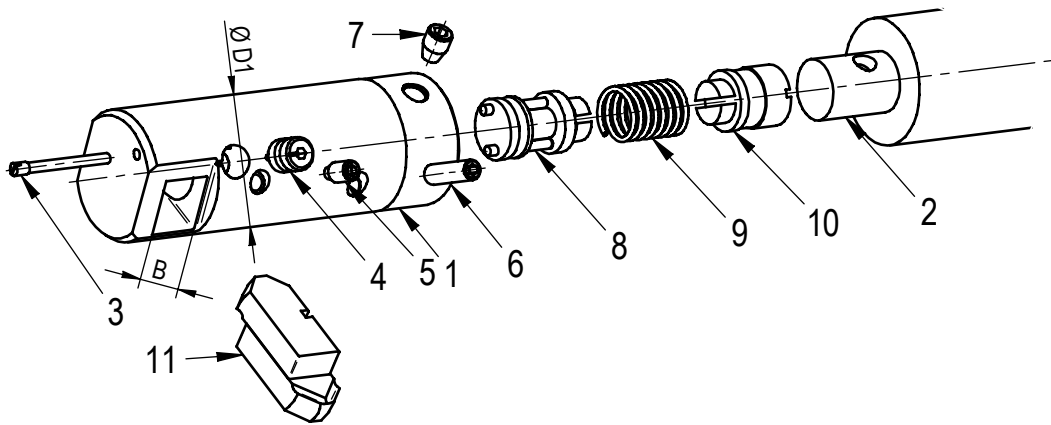

Werkzeug- bezeichnung Tool description	Pos. 1 Grundkörper mit Standard D1 Tool Body with standard D1			Pos. 2 Schäfte Shanks	Pos. 3 Fixierschraube Positioning Screw	Pos. 4 Exzenter Eccentric Cam
	D1	B	Bestell-Nr. Order No. GH-S-G-		Bestell-Nr. Order No. GH-S-X-	Bestell-Nr. Order No. GH-S-E-
<b>GH-S</b>						
<b>18 - 20</b>	16.5	8	0021	siehe Seiten 25-28	0006	0001
<b>20 - 22</b>	18.5	8	0022		0006	0002
<b>22 - 25</b>	20.5	9	0023		0006	0003
<b>25 - 28</b>	23	9	0024		0006	0004
<b>28 - 31</b>	26	10	0025	see pages 25-28	0007	0005
<b>31 - 34</b>	29	10	0026		0007	0006
<b>34 - 38</b>	32	10	0027		0007	0007
<b>38 - 42</b>	36	10	0028		0007	0008

Werkzeug- bezeichnung Tool description	Pos.5 Einstell- schraube Set Screw	Pos.6 Spann- schraube Tension Screw	Pos.7 Klemm- schraube Clamping Screw	Pos. 8 Wippe Blade Control	Pos. 9 Torsionsfeder Torsion Spring	Pos. 10 Spannstück Gear Wheel
	Bestell-Nr. Order No. GH-H-S-	Bestell-Nr. Order No. GH-H-S-	Bestell-Nr. Order No. GH-H-S-	Bestell-Nr. Order No. GH-S-W-	Bestell-Nr. Order No. GH-S-T-	Bestell-Nr. Order No. GH-S-C-
<b>GH-S</b>						
<b>18 - 20</b>	0301	0101	0201	0013	0005	0007
<b>20 - 22</b>	0302	0101	0201	0013	0005	0007
<b>22 - 25</b>	0302	0102	0201	0014	0006	0008
<b>25 - 28</b>	0303	0103	0201	0014	0006	0008
<b>28 - 31</b>	0304	0105	0202	0015	0007	0009
<b>31 - 34</b>	0305	0106	0202	0015	0007	0009
<b>34 - 38</b>	0306	0107	0203	0015	0007	0009
<b>38 - 42</b>	0306	0107	0203	0015	0007	0009

Pos. 11 Messer, siehe Seiten 19-20

Pos. 11 Blades, see pages 19-20

## 11.4 Ersatzteile für GH-S Senkwerkzeuge 42-100 Spare parts for GH-S Chamfering Tools 42-100

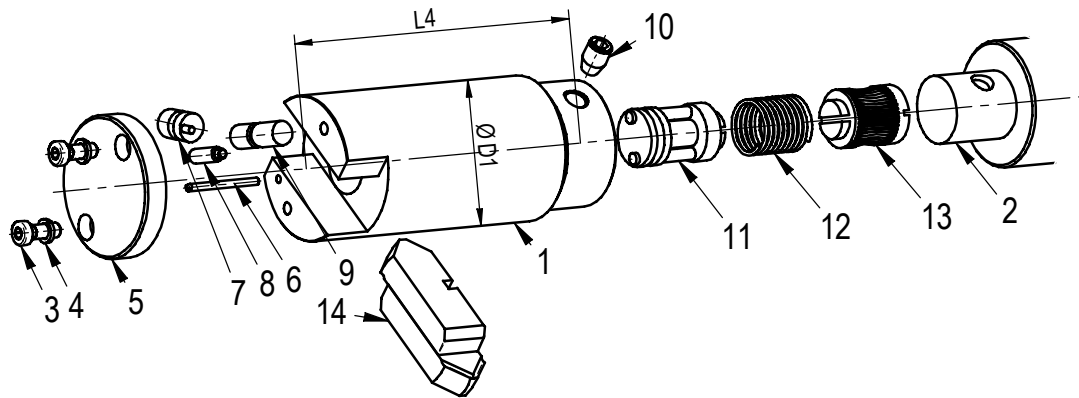

Werkzeug- bezeichnung Tool description	Pos. 1 Grundkörper mit Standard D1 Tool Body with standard D1			Pos. 2 Schäfte Shanks	Pos. 3 Zylinder- schraube Cap Screw	Pos. 4 Federring Spring Washer	Pos. 5 Deckel End Cap	Pos. 6 Fixierstift Pin
	L4	D1	Bestell-Nr. Order No.	Best.-Nr. Order No.	Best.-Nr. Order No.	Best.-Nr. Order No.	Best.-Nr. Order No.	Best.-Nr. Order No.
			GH-S-G-					
<b>GH-S</b>								
<b>42 - 48</b>	122	40	0029	siehe Seiten 29-30	0524	0201	0009	0011
<b>48 - 54</b>	122	46	0030		0524	0201	0010	0011
<b>54 - 62</b>	138	52	0031		0526	0202	0011	0012
<b>62 - 70</b>	138	60	0032		0526	0202	0012	0012
<b>70 - 80</b>	168	68	0033	see pages 29-30	0527	0203	0013	0013
<b>80 - 90</b>	168	78	0034		0527	0203	0014	0013
<b>90 - 100</b>	168	88	0035		0527	0203	0015	0013

Werkzeug- bezeichnung Tool description	Pos. 7 Exzenter Eccentric Cam	Pos. 8 Einstell- schraube Set Screw	Pos. 9 Spann- schraube Tension Screw	Pos. 10 Klemm- schraube Clamping Screw	Pos. 11 Wippe Blade Control	Pos. 12 Torsions- feder Torsion Spring	Pos. 13 Spann- stück Gear Wheel	Pos. 14 Messer Blades
	Best.-Nr. Order No.	Best.-Nr. Order No.	Best.-Nr. Order No.	Best.-Nr. Order No.	Best.-Nr. Order No.	Best.-Nr. Order No.	Best.-Nr. Order No.	
	GH-S-E-	GH-H-S-	GH-S-X-	GH-H-S-	GH-S-W-	GH-S-T-	GH-S-C-	
<b>GH-S</b>								
<b>42 - 48</b>	0009	0311	0014	0204	0016	0009	0010	siehe Seiten 19-20 see pages 19-20
<b>48 - 54</b>	0010	0312	0015	0204	0016	0009	0010	
<b>54 - 62</b>	0011	0313	0016	0205	0017	0010	0011	
<b>62 - 70</b>	0012	0314	0017	0205	0017	0010	0011	
<b>70 - 80</b>	0013	0316	0018	0206	0018	0011	0012	
<b>80 - 90</b>	0014	0317	0019	0206	0018	0011	0012	
<b>90 - 100</b>	0015	0318	0020	0206	0018	0011	0012	

# 11.5 Ersatzteile für GH-S Senkwerkzeuge 6-18 Spare parts for GH-S Chamfering Tools 6-18

(Ausführung für lange Bohrungen)

(Tool types for long bores)

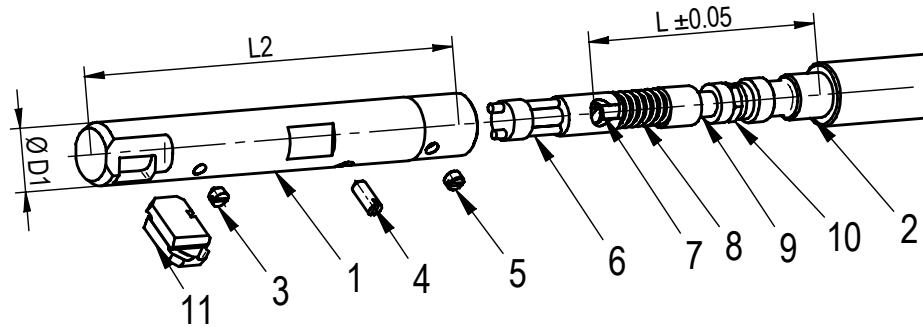

Werkzeug- bezeichnung Tool description	L	Pos. 1 Grundkörper mit Standard D1 Tool Body with standard D1			Schaft zyl.	Schaft zyl., verlängert	MK Schaft	Pos. 3 Einstell- schraube Set Screw	Pos. 4 Spann- schraube Tension Screw
		L2	D1	Bestell-Nr. Order No.	Bestell-Nr. Order No.	Bestell-Nr. Order No.	Bestell-Nr. Order No.	Bestell-Nr. Order No.	Bestell-Nr. Order No.
GH-S				GH-S-G-	GH-S-S-	GH-S-S-	GH-S-S-	GH-H-S-	GH-H-S-
6 - 7	25.2	41	5.8	0002	0003	0070	0004	0406	0401
7 - 8	25.2	41	6.5	0004	0005	0071	0004	0407	0402
8 - 10	31.6	50	7.5	0006	0008	0072	0009	0408	0403
10 - 12	32.6	50.5	9.5	0009	0011	0073	0014	0410	0411
12 - 14	35.7	59	11	0012	0018	0074	0021	0410	0412
14 - 16	35.7	59	13	0015	0023	0075	0025	0415	0417
16 - 18	35.7	59	15	0019	0027	0076	0025	0416	0418

Werkzeug- bezeichnung Tool description	Pos. 5 Anschlag- schraube Stop Screw	Pos. 6 Wippe Blade Control	Pos. 7 Rückzug- schraube Retaining Screw	Pos. 8 Torsionsfeder Torsion Spring	Pos. 9 Spannstück Gear Wheel	Pos. 10 Kontermutter Counter Nut
	Bestell-Nr. Order No.	Bestell-Nr. Order No.	Bestell-Nr. Order No.	Bestell-Nr. Order No.	Bestell-Nr. Order No.	Bestell-Nr. Order No.
GH-S	GH-H-S-	GH-S-W-	GH-S-X-	GH-S-T-	GH-S-C-	GH-H-M-
6 - 7	0404	0006	0002	0002	0002	0001
7 - 8	0405	0006	0002	0002	0002	0001
8 - 10	0405	0006	0002	0002	0003	0001
10 - 12	0409	0007	0003	0003	0004	0002
12 - 14	0409	0010	0003	0004	0005	0002
14 - 16	0413	0010	0003	0004	0006	0002
16 - 18	0414	0010	0003	0004	0006	0002

Pos. 11 Messer, siehe Seite 17-18

Pos. 11 Blades, see pages 17-18

## 12 Zubehör für GH-S / Accessories for GH-S

### 12.1 Nachschärfvorrichtung für GH-S Messer Regrinding devices for GH-S Blades

GH-S Messer werden an der Spanleitstufe nachgeschärft. Mit dieser Nachschärfvorrichtung, aufgespannt auf ihrer Flachsleif- oder Werkzeugschärfmaschine, werden die beiden Schneidmesser optimal und kostensparend nachgeschärft.

Only the chip groove on the GH-S blade is re-ground. With this device clamped to your surface grinder or tool grinding machine, both cutting blades can be efficiently and economically reground.

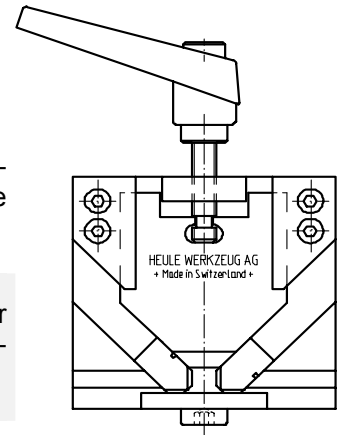

Werkzeug- bezeichnung Tool description	Nachschärfvorrichtung für Faswinkel 90° Regrinding devices for chamfer angle 90°
<b>GH-S</b>	Bestell-Nr. Order No.
<b>4-4.5 bis/to 10-12</b>	GH-S-V-0040
<b>6-7 bis/to 38-42</b>	GH-S-V-0041
<b>42 - 100</b>	GH-S-V-0042

Werkzeug- bezeichnung Tool description	Nachschärfvorrichtung für Faswinkel 60° Regrinding devices for chamfer angle 60°
<b>GH-S</b>	Bestell-Nr. Order No.
<b>4-4.5 bis/to 7-8</b>	GH-S-V-0049
<b>8 - 42</b>	GH-S-V-0050

### 12.2 Austreiblappen für MK Schäfte / Tang for MT Shanks

Austreiblappen für	Tang for	Bestell-Nr. Order No.	Austreiblappen für	Tang for	Bestell-Nr. Order No.
MK 1	MT 1	<b>GH-S-L-0001</b>	MK 3	MT 3	<b>GH-S-L-0003</b>
MK 2	MT 2	<b>GH-S-L-0002</b>	MK 4	MT 4	<b>GH-S-L-0004</b>

### 12.3 Klemmutter (DIN 6327) für Stellhülzenschaft Clamping Nut (DIN 6327) for Automotive Shank

für Trapezgewinde	for trapezoid thread	Bestell-Nr.	Order No.
	Tr 16 x 1.5		GH-H-M-0201
	Tr 20 x 2		GH-H-M-0202
	Tr 25 x 2		GH-H-M-0204
	Tr 28 x 2		GH-H-M-0203

## 13 Fehler, wie beheben / Operational faults, how to rectify

Problem	Ursachen	Behebung
Fase zu klein	<ul style="list-style-type: none"> <li>• Messerkraft zu gering</li> <li>• Vorschub zu hoch</li> <li>• Ungenaue Werkzeugpositionierung im Arbeits- bzw. Eilvorschub</li> </ul>	<ul style="list-style-type: none"> <li>• Messerkraft durch Drehen der Spansschraube nach rechts erhöhen</li> <li>• Vorschub reduzieren</li> <li>• Programmieranleitung und Positionierung auf Seite 5 beachten</li> </ul>
Fase zu gross	<ul style="list-style-type: none"> <li>• Messerkraft zu hoch</li> <li>• Vorschub zu klein</li> </ul>	<ul style="list-style-type: none"> <li>• Messerkraft durch Drehen der Spansschraube nach links reduzieren</li> <li>• Vorschub erhöhen</li> </ul>
Fasengrösse unregelmässig von einem Werkstück zum anderen  Messer wollen beim Messerwechsel nicht einrasten	<ul style="list-style-type: none"> <li>• Messerkraft zu klein</li> <li>• Messer sind abgenutzt</li> <li>• Werkzeug ist noch zu stark gespannt</li> </ul>	<ul style="list-style-type: none"> <li>• Messerkraft durch Drehen der Spansschraube nach rechts erhöhen und gleichzeitig Vorschub erhöhen</li> <li>• neue Messer einsetzen</li> <li>• Werkzeug entspannen: Spansschraube nach links drehen bis die Spansschraube leicht herauskommt</li> </ul>
Werkzeug schneidet schlecht oder gar nicht	<ul style="list-style-type: none"> <li>• Rote Schraubenversiegelung der Einstellschraube wurde entfernt und der D2 ø verstellt</li> </ul>	<ul style="list-style-type: none"> <li>• Messerkraft erhöhen und an der Einstellschraube den D2 ø (siehe Werkzeugtabellen auf Seiten 6-16) wieder einstellen. Schraube wenn möglich wieder versiegeln und Messerkraft reduzieren</li> </ul>

Problem	Reasons	Solution
Chamfer too small	<ul style="list-style-type: none"> <li>• Blade force too small</li> <li>• Feed rate too high</li> <li>• Inaccurate tool positioning in working feed or rapid feed</li> </ul>	<ul style="list-style-type: none"> <li>• Turn tension screw counter-clockwise</li> <li>• Reduce feed rate</li> <li>• Consult programming information and positioning reference on page 5</li> </ul>
Chamfer too large	<ul style="list-style-type: none"> <li>• Blade force too high</li> <li>• Feed rate too small</li> </ul>	<ul style="list-style-type: none"> <li>• Reduce blade force by turning the tension screw counter-clockwise</li> <li>• Increase feed rate</li> </ul>
Chamfer size from one workpiece to another is different	<ul style="list-style-type: none"> <li>• Blade force too small</li> <li>• Blades wear out</li> </ul>	<ul style="list-style-type: none"> <li>• Increase blade force by turning the tension screw clockwise and at the same time increase feed rate</li> <li>• Mount a new set of blades</li> </ul>
Blades do not engage in working position after changing them	<ul style="list-style-type: none"> <li>• Too much tension on the tool</li> </ul>	<ul style="list-style-type: none"> <li>• Reduce tool tension: turn tension screw counter-clockwise until it is slightly loose</li> </ul>
Tool cuts badly or does not cut at all	<ul style="list-style-type: none"> <li>• Red screw sealing was removed from set screw and dia. D2 was changed</li> </ul>	<ul style="list-style-type: none"> <li>• Increase blade force and set the dia. D2 correctly again with the set screw (see tool tables, pages 6-16); seal set screw again if possible and reduce blade force</li> </ul>

# HEULE - Programm

**COFA**  
Entgraten von ebenen und unebenen Bohrungskanten, vor- und rückwärts in einem Arbeitsgang



**COFA**  
Deburring of even and uneven bore edges, forward and reverse in a single work operation





**HEULE**  
**WERKZEUG AG**  
CH-9436 Balgach/Switzerland  
Internet [www.heule.com](http://www.heule.com)  
E-Mail [info@heule.com](mailto:info@heule.com)  
Phone +41 - 71 / 726 38 38  
Fax +41 - 71 / 726 38 39

Die HEULE Werkzeugsysteme sind durch internationale Patente geschützt.  
The HEULE tool systems are protected by international patents.

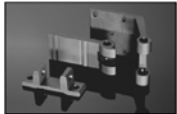
**DEFA**  
Definiertes Fasen von Bohrungen vor- und rückwärts in einem Arbeitsgang

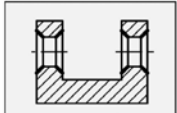
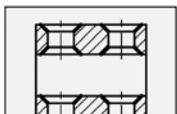

**DEFA**  
Defined bore chamfering forward and reverse in a single work operation

**HEULE**  
**WERKZEUG AG**  
CH-9436 Balgach/Switzerland  
Internet [www.heule.com](http://www.heule.com)  
E-Mail [info@heule.com](mailto:info@heule.com)  
Phone +41 - 71 / 726 38 38  
Fax +41 - 71 / 726 38 39

Die HEULE Werkzeugsysteme sind durch internationale Patente geschützt.  
The HEULE tool systems are protected by international patents.

**SNAP / SNAP-Combi**  
Entgraten vor- und rückwärts kombiniert in einem Werkzeug mit Bohren, Ausspindeln, Fasen, Planenken, etc.

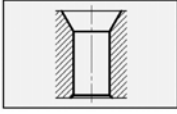
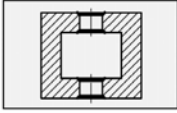

**SNAP / SNAP-Combi**  
Front and back deburring in one single tool in combination with drilling, boring, spotfacing, chamfering, etc.

**HEULE**  
**WERKZEUG AG**  
CH-9436 Balgach/Switzerland  
Internet [www.heule.com](http://www.heule.com)  
E-Mail [info@heule.com](mailto:info@heule.com)  
Phone +41 - 71 / 726 38 38  
Fax +41 - 71 / 726 38 39

Die HEULE Werkzeugsysteme sind durch internationale Patente geschützt.  
The HEULE tool systems are protected by international patents.

**SOLO**  
Einfaches Plan- und Formsenken, vor- und rückwärts in einem Arbeitsgang. Ohne Drehmomentstütze und Maschinenanpassung => sofort einsatzbereit

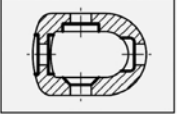
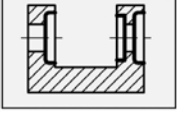

**SOLO**  
Easy front and back spotfacing and formsinking in a single work operation. No anti-rotation device or machine adaptations required => immediately ready for operation

**HEULE**  
**WERKZEUG AG**  
CH-9436 Balgach/Switzerland  
Internet [www.heule.com](http://www.heule.com)  
E-Mail [info@heule.com](mailto:info@heule.com)  
Phone +41 - 71 / 726 38 38  
Fax +41 - 71 / 726 38 39

Die HEULE Werkzeugsysteme sind durch internationale Patente geschützt.  
The HEULE tool systems are protected by international patents.

**HEULE**  
**WERKZEUG AG**  
CH-9436 Balgach/Switzerland

Telephone +41-71/726 38 38  
Telefax +41-71/726 38 39  
Internet [www.heule.com](http://www.heule.com)  
E-Mail [info@heule.com](mailto:info@heule.com)

**USA:**  
**HEULE TOOL CORPORATION**  
4722A Interstate Drive  
Cincinnati, Ohio 45246 / USA

Telephone +1 (513) 860 99 00  
Telefax +1 (513) 860 99 92  
Internet [www.heuletool.com](http://www.heuletool.com)  
E-Mail [usa@heule.com](mailto:usa@heule.com)

**GB:**  
**HEULE TOOL UK LTD**  
Unit 6B / Fir tree lane / Groby  
LE6 0FH Leicester  
Great Britain

Telephone +44(0)116 287 9062  
Telefax +44(0)116 287 1321  
Internet [www.heule.com](http://www.heule.com)  
E-Mail [heule.uk@heule.com](mailto:heule.uk@heule.com)

Die HEULE Werkzeugsysteme sind durch internationale Patente geschützt.  
The HEULE tool systems are protected by international patents.

Vertreten durch:  
Represented by: